

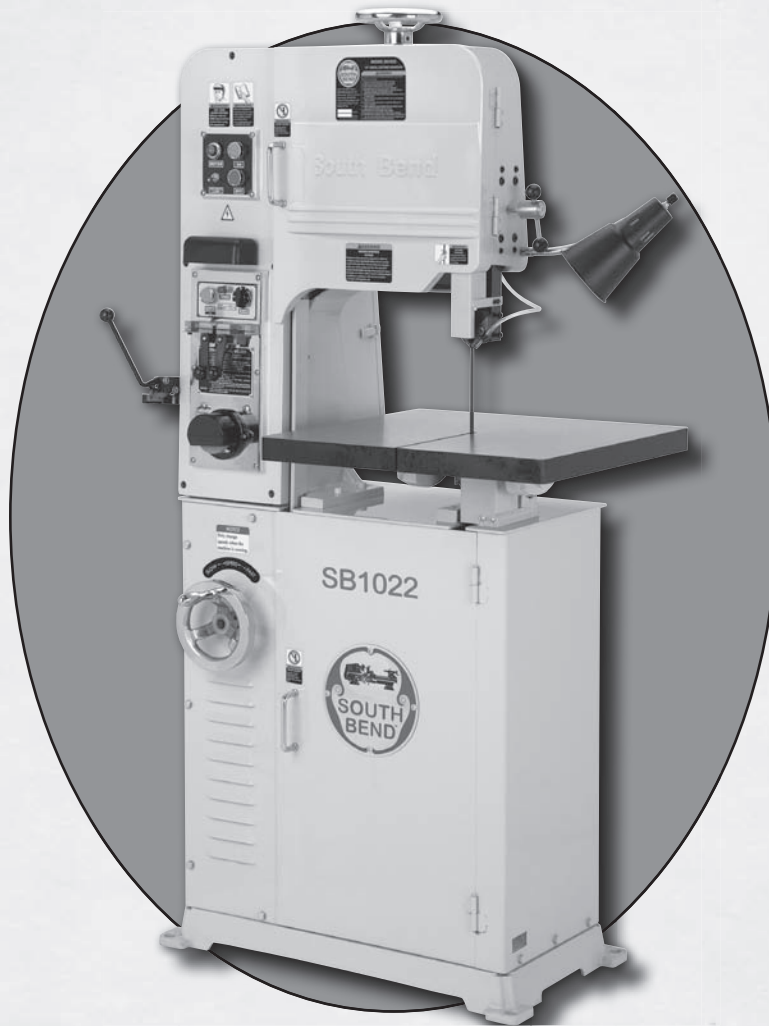

14" METAL CUTTING BANDSAW

MODEL SB1021 - SINGLE PHASE

MODEL SB1022 - THREE PHASE



OWNER'S MANUAL

South Bend Lathe Co.[®]

Hundreds of Thousands of Lathes Sold With a Tradition of Quality Since 1906!



Scope of Manual

This manual helps the reader understand the machine, how to prepare it for operation, how to control it during operation, and how to keep it in good working condition. We assume the reader has a basic understanding of how to operate this type of machine, but that the reader is not familiar with the controls and adjustments of this specific model. As with all machinery of this nature, learning the nuances of operation is a process that happens through training and experience. If you are not an experienced operator of this type of machinery, read through this entire manual, then learn more from an experienced operator, schooling, or research before attempting operations. Following this advice will help you avoid serious personal injury and get the best results from your work.

Manual Feedback

We've made every effort to be accurate when documenting this machine. However, errors sometimes happen or the machine design changes after the documentation process—so the manual may not exactly match your machine. If a difference between the manual and machine leaves you in doubt, contact our customer service for clarification.

We highly value customer feedback on our manuals. If you have a moment, please share your experience using this manual. What did you like about it? Is there anything you would change to make it better? Did it meet your expectations for clarity, professionalism, and ease-of-use?

South Bend Lathe, Inc.
c/o Technical Documentation Manager
P.O. Box 2027
Bellingham, WA 98227
Email: manuals@southbendlathe.com

Updates

For your convenience, any updates to this manual will be available to download free of charge through our website at:

www.southbendlathe.com

Customer Service

We stand behind our machines. If you have any service questions, parts requests or general questions about the machine, feel free to contact us.

South Bend Lathe Co.
P.O. Box 2027
Bellingham, WA 98227
Phone: (360) 734-1540
Parts Department: (417) 886-2954
Fax: (360) 676-1075 (International)
Fax: (360) 734-1639 (USA Only)
Email: cs@southbendlathe.com

Table of Contents

INTRODUCTION.....	2	Blade Care	24
About This Machine.....	2	Blade Break-In	24
Capabilities	2	Blade Speed Chart	25
Features	2	Chip Inspection Chart	25
Identification	3	Positioning Guide Post	26
Machine Specifications	4	Adjusting Blade Guides.....	26
SAFETY.....	8	Tilting Table.....	28
Understanding Risks of Machinery	8	Blade Welding.....	28
Basic Machine Safety	8	MAINTENANCE	32
Additional Metal Cutting Bandsaw Safety	10	Maintenance Schedule.....	32
PREPARATION	11	Cleaning	32
Preparation Overview.....	11	Dressing Grinding Wheel	32
Things You'll Need.....	11	Lubrication	33
Unpacking	11	V-Belts	34
Cleaning & Protecting	12	Speed Hub Belts	34
Location	13	Sprocket Drive Belt	34
Lifting & Moving.....	14	Air Pump Belt	34
Leveling & Mounting.....	14	Dressing Rubber Tires.....	34
Leveling	14	SERVICE.....	35
Bolting to Concrete Floors.....	15	Blade Tracking.....	35
Machine Mounts	15	Table Calibration	35
Assembly	15	Guide Post Alignment.....	36
Initial Lubrication	15	Pinion Gear Backlash	37
Inspections & Adjustments	15	Leadscrew End Play	37
Power Connection	16	TROUBLESHOOTING	38
220V Conversion for SB1021.....	16	ELECTRICAL.....	42
SB1021 110V (Prewired) Power Source	16	Electrical Safety Instructions	42
SB1021 (220V) Power Source	16	Wiring Overview	43
SB1022 (220V 3-Phase) Power Source	16	SB1021/2 Control Panel & Welding Unit	44
Test Run	17	SB1021 110V Electrical Panel, Motor & Cord ..	45
OPERATION.....	18	SB1021 220V Electrical Panel, Motor & Cord ..	46
Operation Overview.....	18	SB1022 220V Electrical Panel, Motor & Cord ..	47
Controls	19	Electrical Component Pictures.....	48
Blade Selection.....	20	PARTS.....	49
Blade Terminology.....	20	Lower Frame	49
Blade Length	20	Drive System.....	51
Blade Width	20	Upper Frame.....	53
Tooth Set.....	21	Table & Tensioning System	55
Tooth Type	21	Electrical Cabinet	57
Blade Pitch (TPI).....	22	Welder & Control Panel	58
Blade Changes	23	Machine Labels	60
Blade Tensioning	23	WARRANTY & RETURNS.....	61
Blade Breakage.....	24		
Blade Care & Break-In.....	24		

About This Machine

Capabilities

This 14" Metal-Cutting Bandsaw allows you to make exterior and interior contoured or straight cuts. To better understand these capabilities, imagine making a "doughnut" out of 1" steel plate.

The outside circular shape can be easily cut by moving the workpiece around the blade, using a pre-drawn line as a cutting guide.

Cutting the inside hole would normally be a difficult task with a bandsaw. But this machine makes it easy. First, the bandsaw blade is cut with the built-in blade shear. A hole slightly larger than the blade is then drilled into the center of the workpiece, so the blade can be threaded through the hole. The ends of the blade are then clamped into the built-in welder, welded back together, annealed, and ground flat with the built-in grinder. Once the blade is re-installed on the wheels, it can then be used to cut the interior hole and complete the doughnut shape. After completion, the blade is sheared again to remove it from the workpiece.

Aside from the above capabilities, this machine can also be used for straight cuts in sheets too large to fit in the vise of a horizontal metal-cutting bandsaw

For example, if you needed to cut a 24" x 24" sheet of 1" steel in half, you can clamp a straightedge to the bandsaw table, then guide the sheet along the straightedge to make a nice straight cut. Cutting this same size of stock on a horizontal bandsaw would require a very large machine.

On the other hand, if you need to "resaw" an 8" x 8" billet into a series of 1" thick plates, clamp a straightedge 1" away from the blade, raise the blade guides to accommodate the height of the billet, and each cut you make will produce an 8" x 1" plate.

Both of these types of straight cuts can also be made with the table tilted to 15°, which creates a beveled cut.

Features

Now that you know the basics of what this machine can do, take a minute to consider its features.

This machine is equipped with a built-in air blower near the blade guides. This feature keeps metal chips away from the cutting area, so you can accurately follow pre-drawn cutting lines without metal chips getting in the way.

An adjustable work lamp is also provided above the table to eliminate shadows from the work area. This is a great feature when doing close up work near moving blades!

We also equipped this bandsaw with variable speed, so you can precisely control cutting results for the type of blade installed and type of material being cut. This is a great feature to have when doing precision cutting.

Aside from features, we designed this machine to be extremely solid and durable. We used heavy gauge steel for the wheel doors, ridiculously thick table trunnions and frame castings, USA-made Allen-Bradley electronics, and Japanese-made NSK ball bearings.

Identification

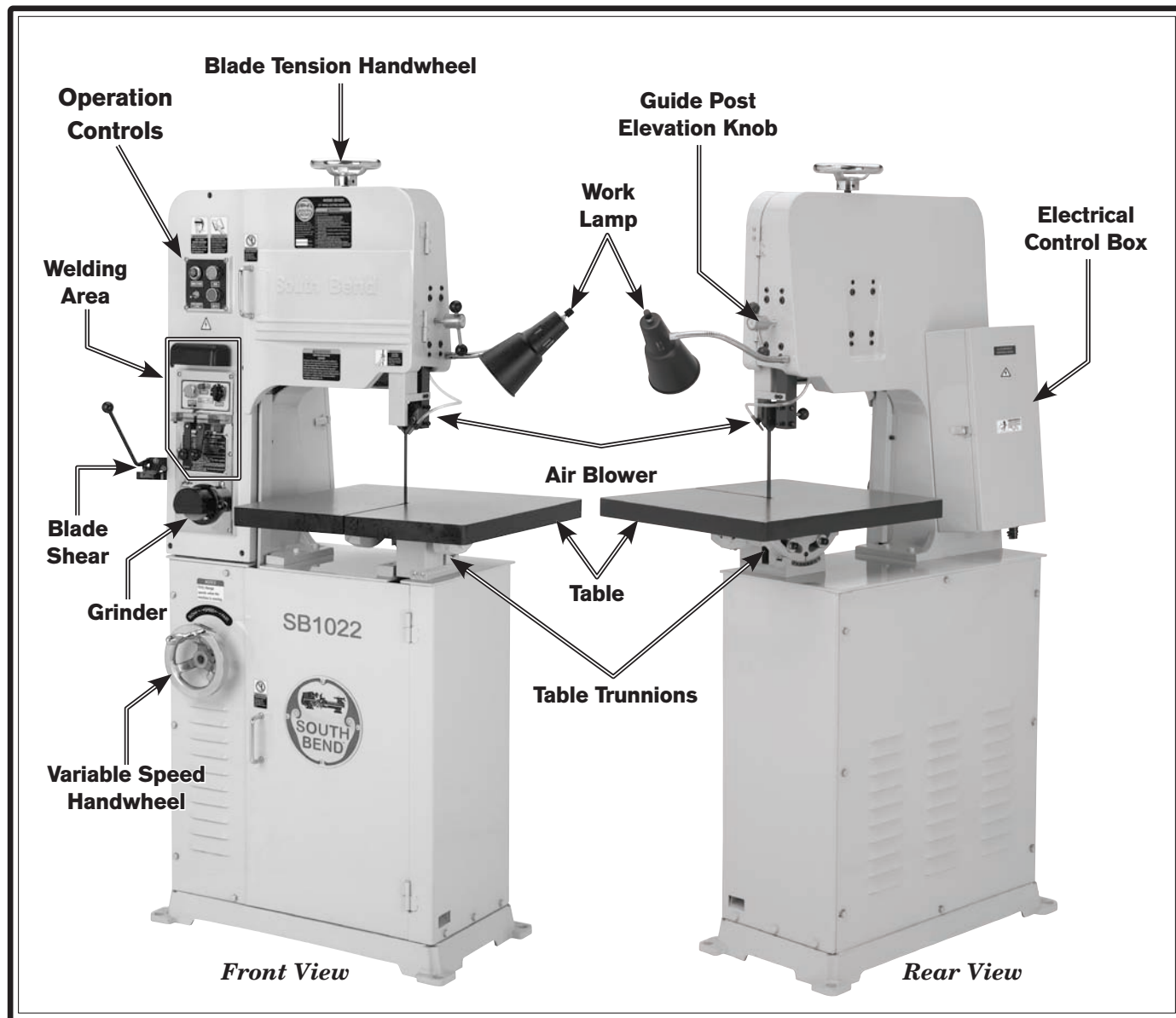

⚠ WARNING
 Serious personal injury could occur if you connect the machine to power before completing the setup process. **DO NOT** connect power until instructed to do so later in this manual.

⚠ WARNING
 Untrained users have an increased risk of seriously injuring themselves with this machine. Do not operate this machine until you have understood this entire manual and received proper training.



Machine Specifications

P.O. Box 2027, Bellingham, WA 98227 U.S.A.
 PHONE: (360) 734-1540 • © South Bend Lathe Co.
www.southbendlathe.com



Model SB1021 14" Variable Speed Vertical Metal Cutting Bandsaw

Product Dimensions:

Weight 697 lbs.
 Length/Width/Height 22" x 36" x 67½"
 Foot Print (Length/Width) 16¼" x 31"

Shipping Dimensions:

Type Wood
 Content Machine
 Weight 926 lbs.
 Length/Width/Height 77" x 42" x 29"

Electrical:

Required Power Source 110/220V, Single-Phase
 Switch Magnetic Contactor with Thermal Overload Relay
 Switch Voltage 110/220V
 Included Plug Type NEMA 5-15
 Recommended Circuit Size 15A

Motors:

Main

Type TEFC Capacitor Start Induction
 Horsepower 1 HP
 Voltage 110/220V
 Phase Single
 Amps 6A @ 220V/12A @ 110V
 Speed 1725 RPM
 Cycle 60 Hz
 Number Of Speeds 1
 Power Transfer Belt Drive
 Bearings Shielded and Permanently Lubricated

Grinder

Type Open Drip Proof Induction
 Horsepower ¼ HP
 Voltage 110V
 Phase Single
 Amps 0.6A
 Speed 3450 RPM
 Cycle 60 Hz
 Number Of Speeds 1
 Power Transfer Direct Drive
 Bearings Sealed and Lubricated

Main Specifications:**Operation Information**

Number of Blade Speeds	Variable
Blade Speed Range	88–384 FPM
Blade Size Range	1/8"–1/2"
Blade Length Range	118 1/4"–119 1/2"

Cutting Capacity

Maximum Cutting Height	7 7/8"
Cutting Capacity Left of Blade	14 1/8"

Table Information

Table Tilt	15° Left/Right, 10° Forward/Back
Table Size	22 1/8"W x 19 7/8" L x 1 5/8" Thick
Floor to Table Height	39 1/2"

Construction

Table	Precision Ground Cast Iron
Wheels	Balanced Cast Iron
Tires	Rubber
Blade Guide	Hardened Steel/Tungsten
Body (Upper)	Cast Iron
Body (Lower)	Steel
Base	Cast Iron
Wheel Cover (Upper)	Cast Aluminum
Wheel Cover (Lower)	Pre-Formed Steel
Wheel Bearings	Japanese NSK Shielded and Permanently Lubricated
Paint	Urethane

Other Related Information

Wheel Diameter	14 1/8"
Electric Blade Welder	220V, 2.0 KVA
Annealing Voltage	220V

Other Specifications:

Country Of Origin	Taiwan
Warranty	1 Year
Serial Number Location	ID Label on Upper Wheel Door
Assembly Time	1 Hour

Features:

Allen Bradley Controls
 Welding Station for Joining Blade Ends
 Includes Blade Cutter, Electric Welder w/Clamp, Annealer, and Grinder
 Infinitely Variable Cutting Speeds
 Lower Wheel Cleaning Brush
 Work Light
 Chip Blower
 Rubber Bonded Saw Wheels

	<h1>Machine Specifications</h1>	
P.O. Box 2027, Bellingham, WA 98227 U.S.A. PHONE: (360) 734-1540 • © South Bend Lathe Co. www.southbendlathe.com		

Model SB1022 14" Variable Speed Vertical Metal Cutting Bandsaw

Product Dimensions:

Weight697 lbs.
 Length/Width/Height 22" x 36" x 67½"
 Foot Print (Length/Width) 16¼" x 31"

Shipping Dimensions:

TypeWood
 Content..... Machine
 Weight 926 lbs.
 Length/Width/Height 77" x 42" x 29"

Electrical:

Required Power Source 220V, 3-Phase
 Switch..... Magnetic Contactor with Thermal Overload Relay
 Switch Voltage 220V
 Cord Included No
 Recommended Cord Type..... 16 Gauge, 4 Wire, 300VAC
 Recommended Plug Type..... NEMA L15-15
 Recommended Circuit Size 15 amp

Motors:

Main

TypeTEFC Capacitor Start Induction
 Horsepower..... 1 HP
 Voltage..... 220V
 Phase Three
 Amps 3A
 Speed..... 1725 RPM
 Cycle 60 Hz
 Number Of Speeds 1
 Power Transfer..... Belt Drive
 Bearings..... Shielded and Permanently Lubricated

Grinder

Type Open Drip Proof Induction
 Horsepower..... ¼ HP
 Voltage..... 110V
 Phase Single
 Amps 0.6A
 Speed..... 3450 RPM
 Cycle 60 Hz
 Number Of Speeds 1
 Power Transfer..... Direct Drive
 Bearings..... Sealed and Lubricated

Main Specifications:**Operation Information**

Number of Blade Speeds	Variable
Blade Speed Range	88–384 FPM
Blade Size Range	$\frac{1}{8}$ "– $\frac{1}{2}$ "
Blade Length Range	118 $\frac{1}{4}$ "–119 $\frac{1}{2}$ "

Cutting Capacity

Maximum Cutting Height	7 $\frac{7}{8}$ "
Cutting Capacity Left of Blade	14 $\frac{1}{8}$ "

Table Information

Table Tilt	15° Left/Right, 10° Forward/Back
Table Size	22 $\frac{1}{8}$ "W x 19 $\frac{7}{8}$ " L x 1 $\frac{5}{8}$ " Thick
Floor to Table Height	39 $\frac{1}{2}$ "

Construction

Table	Precision Ground Cast Iron
Wheels	Balanced Cast Iron
Tires	Rubber
Blade Guide	Hardened Steel/Tungsten
Body (Upper)	Cast Iron
Body (Lower)	Steel
Base	Cast Iron
Wheel Cover (Upper)	Cast Aluminum
Wheel Cover (Lower)	Pre-Formed Steel
Wheel Bearings	Shielded and Permanently Lubricated
Paint	Urethane

Other Related Information

Wheel Diameter	14 $\frac{1}{8}$ "
Electric Blade Welder	220V, 2.0 KVA
Annealing Voltage	220V

Other Specifications:

Country Of Origin	Taiwan
Warranty	1 Year
Serial Number Location	ID Label on Upper Wheel Door
Assembly Time	1 Hour

Features:

Allen Bradley Controls
 Welding Station for Joining Blade Ends
 Includes Blade Cutter, Electric Welder w/ Clamp, Annealer, and Grinder
 Infinitely Variable Cutting Speeds
 Lower Wheel Cleaning Brush
 Work Light
 Chip Blower
 Rubber Bonded Saw Wheels



Understanding Risks of Machinery

Operating all machinery and machining equipment can be dangerous or relatively safe depending on how it is installed and maintained, and the operator's experience, common sense, risk awareness, working conditions, and use of personal protective equipment (safety glasses, respirators, etc.).

The owner of this machinery or equipment is ultimately responsible for its safe use. This responsibility includes proper installation in a safe environment, personnel training and usage authorization, regular inspection and maintenance, manual availability and comprehension, application of safety devices, integrity of cutting tools or accessories, and the usage of approved personal protective equipment by all operators and bystanders.

The manufacturer of this machinery or equipment will not be held liable for injury or property damage from negligence, improper training, machine modifications, or misuse. Failure to read, understand, and follow the manual and safety labels may result in serious personal injury, including amputation, broken bones, electrocution, or death.

The signals used in this manual to identify hazard levels are defined as follows:

 DANGER	<i>Death or catastrophic harm WILL occur.</i>	 CAUTION	<i>Moderate injury or fire MAY occur.</i>
 WARNING	<i>Death or catastrophic harm COULD occur.</i>	NOTICE	<i>Machine or property damage may occur.</i>

Basic Machine Safety

- 1. Owner's Manual:** All machinery and machining equipment presents serious injury hazards to untrained users. To reduce the risk of injury, anyone who uses THIS item MUST read and understand this entire manual before starting.
- 2. Personal Protective Equipment:** Operating or servicing this item may expose the user to flying debris, dust, smoke, dangerous chemicals, or loud noises. These hazards can result in eye injury, blindness, long-term respiratory damage, poisoning, cancer, reproductive harm or hearing loss. Reduce your risks from these hazards by wearing approved eye protection, respirator, gloves, or hearing protection.
- 3. Trained/Supervised Operators Only:** Untrained users can seriously injure themselves or bystanders. Only allow trained and properly supervised personnel to operate this item. Make sure safe operation instructions are clearly understood. If electrically powered, use padlocks and master switches, and remove start switch keys to prevent unauthorized use or accidental starting.
- 4. Guards/Covers:** Accidental contact with moving parts during operation may cause severe entanglement, impact, cutting, or crushing injuries. Reduce this risk by keeping any included guards/covers/doors installed, fully functional, and positioned for maximum protection.

- 5. Entanglement:** Loose clothing, gloves, neckties, jewelry or long hair may get caught in moving parts, causing entanglement, amputation, crushing, or strangulation. Reduce this risk by removing/securing these items so they cannot contact moving parts.
- 6. Mental Alertness:** Operating this item with reduced mental alertness increases the risk of accidental injury. Do not let a temporary influence or distraction lead to a permanent disability! Never operate when under the influence of drugs/alcohol, when tired, or otherwise distracted.
- 7. Safe Environment:** Operating electrically powered equipment in a wet environment may result in electrocution; operating near highly flammable materials may result in a fire or explosion. Only operate this item in a dry location that is free from flammable materials.
- 8. Electrical Connection:** With electrically powered equipment, improper connections to the power source may result in electrocution or fire. Always adhere to all electrical requirements and applicable codes when connecting to the power source. Have all work inspected by a qualified electrician to minimize risk.
- 9. Disconnect Power:** Adjusting or servicing electrically powered equipment while it is connected to the power source greatly increases the risk of injury from accidental startup. Always disconnect power **BEFORE** any service or adjustments, including changing blades or other tooling.
- 10. Secure Workpiece/Tooling:** Loose workpieces, cutting tools, or rotating spindles can become dangerous projectiles if not secured or if they hit another object during operation. Reduce the risk of this hazard by verifying that all fastening devices are properly secured and items attached to spindles have enough clearance to safely rotate.
- 11. Chuck Keys or Adjusting Tools:** Tools used to adjust spindles, chucks, or any moving/rotating parts will become dangerous projectiles if left in place when the machine is started. Reduce this risk by developing the habit of always removing these tools immediately after using them.
- 12. Work Area:** Clutter and dark shadows increase the risks of accidental injury. Only operate this item in a clean, non-glaring, and well-lighted work area.
- 13. Properly Functioning Equipment:** Poorly maintained, damaged, or malfunctioning equipment has higher risks of causing serious personal injury compared to those that are properly maintained. To reduce this risk, always maintain this item to the highest standards and promptly repair/service a damaged or malfunctioning component. Always follow the maintenance instructions included in this documentation.
- 14. Unattended Operation:** Electrically powered equipment that is left unattended while running cannot be controlled and is dangerous to bystanders. Always turn the power **OFF** before walking away.
- 15. Health Hazards:** Certain cutting fluids and lubricants, or dust/smoke created when cutting, may contain chemicals known to the State of California to cause cancer, respiratory problems, birth defects, or other reproductive harm. Minimize exposure to these chemicals by wearing approved personal protective equipment and operating in a well ventilated area.
- 16. Difficult Operations:** Attempting difficult operations with which you are unfamiliar increases the risk of injury. If you experience difficulties performing the intended operation, **STOP!** Seek an alternative method to accomplish the same task, ask a qualified expert how the operation should be performed, or contact our Technical Support for assistance.

Additional Metal Cutting Bandsaw Safety

- 1. Blade Condition:** Do not operate with a dull, cracked or badly worn blade—they can break during use or greatly decrease cutting performance. Inspect blades for cracks and missing teeth before each use.
- 2. Blade Replacement:** Wear gloves to protect hands and safety glasses to protect eyes when replacing the blade. When replacing blades, make sure teeth face forward and down toward the table in the direction of blade travel.
- 3. Workpiece Handling:** Your hands can be cut or drawn into the blade during operation if the workpiece moves unexpectedly. Always keep your hands a safe distance away from the moving blade.
- 4. Welding And Grinding Safety:** The welding station can be hazardous if used incorrectly and without proper personal protection. Always wear welding-approved gloves, eye protection, and clothing when welding blades. Touching any metal parts of the blade, welder, or machine when activating the welder could lead to electrocution. Welding near flammables could cause a fire.
- 5. Hot Surfaces:** Be aware that touching hot workpieces or chips after welding, grinding, or cutting can cause burns.
- 6. Cutting Fluid Safety:** This machine is designed for dry cutting operations. Flood-type cutting fluid setups should not be used because the machine is not waterproof.
- 7. Magnesium Fire Hazard:** Use EXTREME CAUTION if cutting magnesium. Using the wrong cutting fluid or overheating the material could lead to an extremely hot fire that is difficult to extinguish. Additionally, do not allow magnesium swarf or dust to pile up around the machine and only dispose of the waste using approved methods.
- 8. Entanglement Hazards:** Always keep the blade guard correctly positioned and wheel doors closed and secured when bandsaw is in operation. Loose clothing, jewelry, long hair and work gloves can be drawn into working parts.
- 9. Maintenance/Service:** All inspections, adjustments, and maintenance are to be done with the power OFF and the plug pulled from the outlet. Wait for all moving parts to come to a complete stop.
- 10. Unstable Workpieces:** Workpieces that cannot be supported or stabilized without a vise or jig should not be cut on a vertical metal-cutting bandsaw, because they can unexpectedly move while cutting and draw the operator's hands into the blade causing serious personal injury. Examples are chains, cables, round or oblong-shaped workpieces, workpieces with internal or built-in moving or rotations parts, etc.
- 11. Clearing Chips:** Metal chips can easily cut skin—even through a piece of cloth. Avoid clearing chips by hand or with a rag. Use a brush or vacuum to clear metal chips.

Preparation Overview

The purpose of the preparation section is to help you prepare your machine for operation.

The typical preparation process is as follows:

1. Unpack the machine and inventory the contents of the box/crate.
2. Clean the machine and its components.
3. Identify an acceptable location for the machine and move it to that location.
4. Level the machine and either bolt it to the floor or place it on mounts.
5. Assemble the loose components and make any necessary adjustments or inspections to ensure the machine is ready for operation.
6. Connect the machine to the power source.
7. Test run the machine to make sure it functions properly and is ready for operation.

Things You'll Need

During the setup process, operation, and maintenance of your machine, you'll need the following items:

For Lifting

- A forklift or other power lifting device rated for the weight of the machine.
- Lifting Strap or Chain (rated for at least 1000 lbs.)

For Power Connection

- A qualified electrician to ensure a safe and code-compliant connection to the power source. (Refer to **Page 16** for details.)

For Assembly

- Cotton Rags
- Mineral Spirits
- Safety Glasses
- Oil Can with any General Machine Oil
- Blade Tension Tool
- Grease Gun with any API GL 2 Grease
- Stiff Grease Brush
- Phillips Screwdriver #2
- Floor Mounting Hardware As Needed
- Hex Wrench 5mm
- Hex Wrench 6mm
- Combo Wrench 1/2" or Ratchet and 1/2" Socket

Unpacking

This item was carefully packaged to prevent damage during transport. If you discover any damage, please immediately call Customer Service at (360) 734-1540 for advice. You may need to file a freight claim, so save the containers and all packing materials for possible inspection by the carrier or its agent.

Cleaning & Protecting

The unpainted surfaces are coated at the factory with a heavy-duty rust preventative that prevents corrosion during shipment and storage. The benefit of this rust preventative is that it works very well. The downside is that it can be time-consuming to thoroughly remove.

Be patient and do a careful job when cleaning and removing the rust preventative. The time you spend doing this will reward you with smooth-sliding parts and a better appreciation for the proper care of the unpainted surfaces.

Although there are many ways to successfully remove the rust preventative, we have cleaned thousands of machines and found the following process to be the best balance between efficiency and minimized exposure to toxic fumes or chemicals.

Before cleaning, gather the following:

- Disposable rags
- Cleaner/degreaser (certain citrus-based degreasers work extremely well and they have non-toxic fumes)
- Safety glasses & disposable gloves

Note: Automotive degreasers, mineral spirits, or WD•40 can be used to remove rust preventative. Before using these products, though, test them on an inconspicuous area of a painted area to make sure they will not damage it.

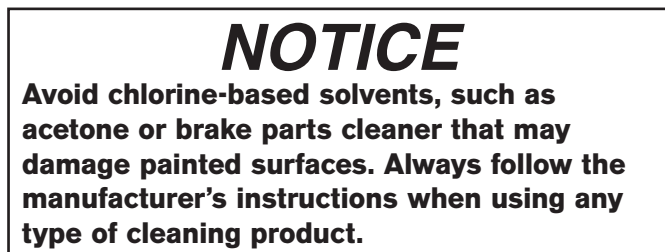
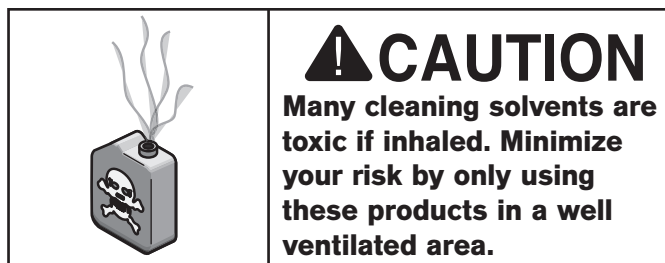
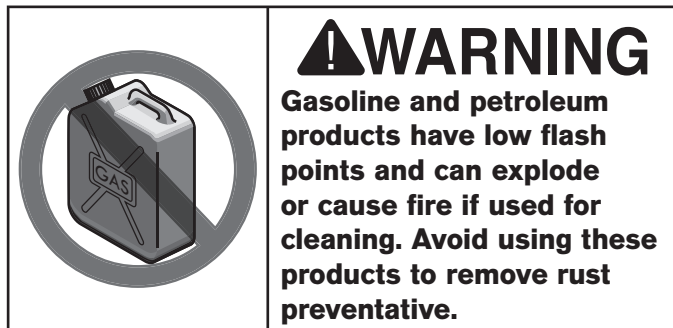

Basic steps for removing rust preventative:

1. Put on safety glasses and disposable gloves.
 2. Coat all surfaces that have rust preventative with a liberal amount of your cleaner or degreaser and let them soak for a few minutes.
 3. Wipe off the surfaces. If your cleaner or degreaser is effective, the rust preventative will wipe off easily.
- Note:** To clean off thick coats of rust preventative on flat surfaces, such as beds or tables, use a PLASTIC paint scraper to scrape off the majority of the coating before wiping it off with your rag. (Do not use a metal scraper or it may scratch the surface.)
4. Repeat **Steps 2–3** as necessary until clean, then coat all unpainted surfaces with a quality metal protectant or light oil to prevent rust.

Location

Physical Environment

The physical environment where your machine is operated is important for safe operation and longevity of parts. For best results, operate this machine in a dry environment that is free from excessive moisture, hazardous or flammable chemicals, airborne abrasives, or extreme conditions. Extreme conditions for this type of machinery are generally those where the ambient temperature is outside the range of 41°–104°F; the relative humidity is outside the range of 20–95% (non-condensing); or the environment is subject to vibration, shocks, or bumps.

Electrical Installation

Place this machine near an existing power source. Make sure all power cords are protected from traffic, material handling, moisture, chemicals, or other hazards. Make sure to leave access to a means of disconnecting the power source or engaging a lockout/tagout device.

Lighting

Lighting around the machine must be adequate enough that operations can be performed safely. Shadows, glare, or strobe effects that may distract or impede the operator must be eliminated.

Weight Load

Refer to the **Machine Specifications** for the weight of your machine. Make sure that the surface upon which the machine is placed will bear the weight of the machine, additional equipment that may be installed on the machine, and the heaviest workpiece that will be used. Additionally, consider the weight of the operator and any dynamic loading that may occur when operating the machine.

Space Allocation

Consider the largest size of workpiece that will be processed through this machine and provide enough space around the machine for adequate operator material handling or the installation of auxiliary equipment. With permanent installations, leave enough space around the machine to open or remove doors/covers as required by the maintenance and service described in this manual.

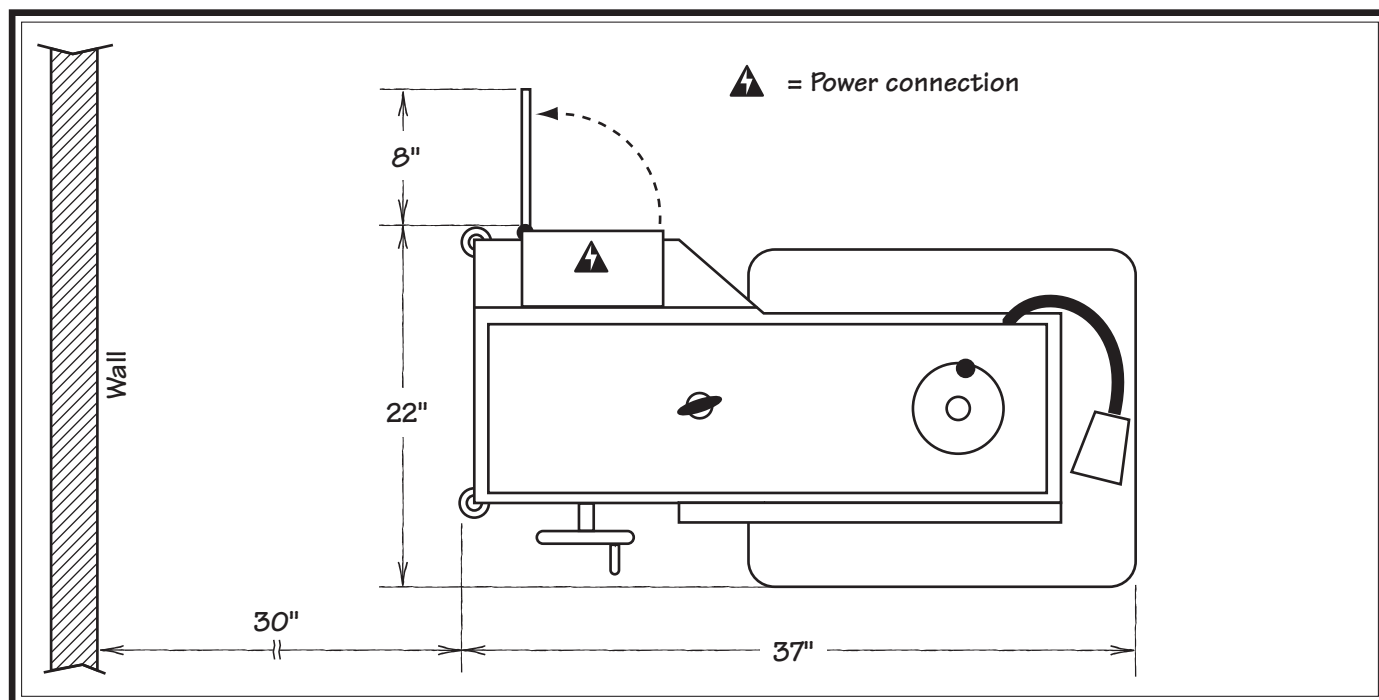
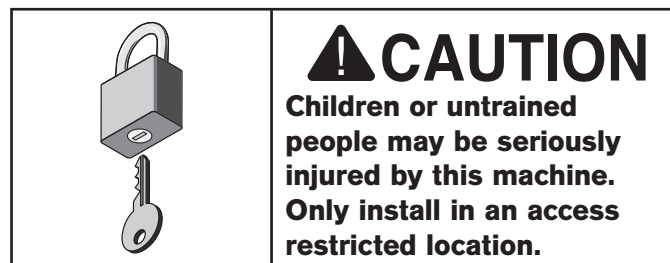
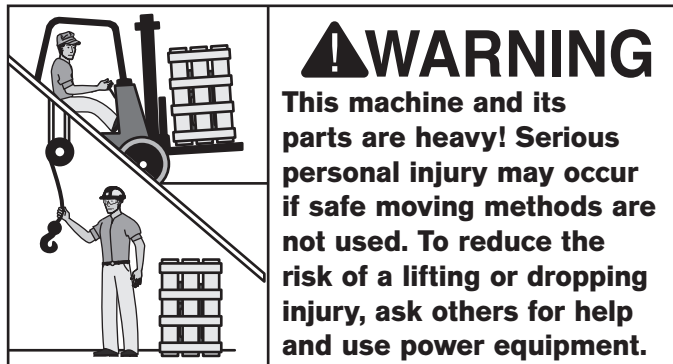

Figure 1. Clearances.

Lifting & Moving



Use a forklift to lift the machine off the pallet and onto a suitable location using the lifting eye shown in **Figure 2**.



Figure 2. Lifting location.

Leveling & Mounting

Generally, you can either bolt your machine to the floor or mount it on machine mounts. Although not required, we recommend that you secure the machine to the floor and level it while doing so. Because this is an optional step and floor materials may vary, hardware for securing the machine to the floor is not included.

NOTICE

We strongly recommend securing your machine to the floor if it is hardwired to the power source. Consult with your electrician to ensure compliance with local codes.

Leveling

Leveling machinery helps precision components, such as bed ways, remain straight and flat during the lifespan of the machine. Components on an unlevelled machine may slowly twist due to the dynamic loads placed on the machine during operation.

For best results, use a precision level that is at least 12" long and sensitive enough to show a distinct movement when a 0.003" shim (approximately the thickness of one sheet of standard newspaper) is placed under one end of the level.

See the figure below for an example of a high precision level.

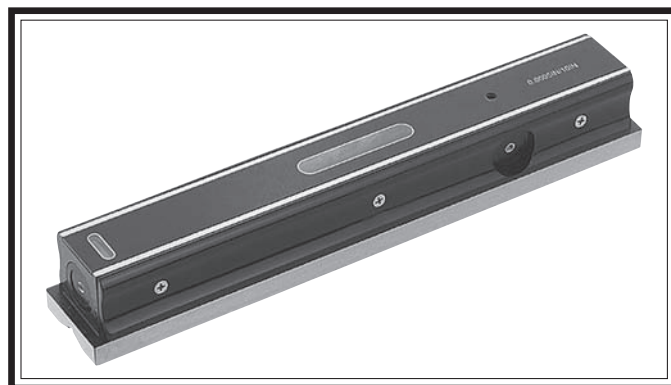

Figure 3. Example of a precision level.

Bolting to Concrete Floors

Lag screws and anchors, or anchor studs (**below**), are two popular methods for securing machinery to a concrete floor. We suggest you research the many options and methods for securing your machine and choose the best one for your specific application.

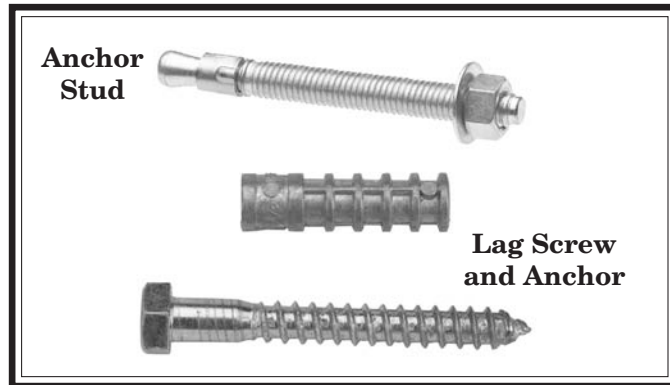

Figure 4. Common types of fasteners for bolting machinery to concrete floors.

Machine Mounts

Machine mounts are rubber pads mounted to a threaded stud, which can be fastened to the bottom of the machine.

Machine mounts offer certain advantages such as ease of installation, vibration dampening, and easy leveling. They also make it easier to relocate the machine later on.

The disadvantage of machine mounts is that the machine can shift or move over time. For this reason, electrical codes may limit their use if the machine is hardwired to the power source. Also, mounts may reduce the total surface area of machine-to-floor contact, depending on the design of the machine.



Figure 5. Typical machine mount.

Assembly

This machine comes pre-assembled from the factory. However, tension has been removed from the blade for shipping purposes. Before operating the machine for the first time, you **MUST** make sure the blade is properly tensioned. Refer to the **Blade Tensioning** procedure on **Page 23** for instructions about how to do this.

Initial Lubrication

Your machine was lubricated at the factory, but we strongly recommend that you inspect all lubrication points yourself and provide additional lubrication if necessary. Refer to **Lubrication** on **Page 33** for specific details.

Inspections & Adjustments

The following list of adjustments were performed at the factory before your machine was shipped:

- **Blade Guide Adjustment**Page 26
- **V-Belt Adjustment**Page 34
- **Table Calibration**Page 35
- **Blade Tracking**.....Page 35
- **Guide Post Alignment**Page 36

Be aware that machine components can shift during the shipping process. Pay careful attention to these adjustments as you test run your machine. If you find that the adjustments are not set according to the procedures in this manual or your personal preferences, re-adjust them.

Power Connection



! WARNING

Electrocution or fire may occur if machine is ungrounded, incorrectly connected to power, or connected to an undersized circuit. Use a qualified electrician to ensure a safe power connection.

Once your machine is set up and assembled as previously described in this manual, it is ready to be connected to the power source.

Use the information in this section to determine the power source requirements needed to operate this machine. If your existing power source does not meet the stated requirements, consult with a qualified electrician about running a new circuit.

Note About Extension Cords: Using an incorrectly sized extension cord may decrease the life of electrical components on your machine.

Note About 3-Phase Power (SB1022 Only): DO NOT use a static phase converter to create 3-phase power—it can quickly decrease the life of electrical components on your machine. If you must use a phase converter, only use a rotary phase converter and connect the wild wire to the correct power connection terminal, shown in the wiring diagram on **Page 47**.

220V Conversion for SB1021

Wiring diagrams are provided on **Pages 44 and 46** in this manual, showing the Model SB1021 wired for both 110V and 220V. Refer to these diagrams when following this procedure.

To convert the Model SB1021 to operate on 220V:

1. DISCONNECT BANDSAW FROM POWER!
2. Rewire the motor for 220V, as shown in the diagram on the inside of the motor junction box. If there is not a diagram in the junction box, use the motor wiring diagram in this manual (see **Page 46**).

3. Locate the power transformer in the electrical panel (see **Page 48, Figure 50**) and remove the wire attached to the 110V terminal and connect it to the 220V terminal.
4. Turn the dial on the overload relay (see **Page 48, Figure 50**) from 14A for 110V to 7A for 220V.
5. Locate the welding transformer in the control panel (see **Page 48, Figure 49**). Remove the wire connected to the #2 terminal and move it to the #5 terminal; remove the wire connected to the #4 terminal and move it to the #7 terminal.
6. The machine is now wired for 220V.

SB1021 110V (Prewired) Power Source

Full Load Amp Draw	13.6 Amps
Permissible Voltage Range.....	99V–121V
Phase	Single-Phase
Frequency	60 Hz
Minimum Circuit Size	20 Amps
Included Plug	NEMA 5-15
Minimum Extension Cord Size	14 AWG
Maximum Extension Cord Length.....	50 ft.

SB1021 (220V) Power Source

Full Load Amp Draw	6.8 Amps
Permissible Voltage Range.....	198V–242V
Phase	Single-Phase
Frequency	60 Hz
Minimum Circuit Size	15 Amps
Recommended Plug/Receptacle	NEMA 6-15
Minimum Extension Cord Size	14 AWG
Maximum Extension Cord Length.....	50 ft.

SB1022 (220V 3-Phase) Power Source

Full Load Amp Draw	3.6 Amps
Permissible Voltage Range.....	198V–242V
Phase	3-Phase
Frequency	60 Hz
Minimum Circuit Size	15 Amps
Recommended Plug/Receptacle	NEMA L15-15
Minimum Extension Cord Size	16 AWG
Maximum Extension Cord Length.....	50 ft.

Test Run

After all preparation steps have been completed, the machine and its safety features must be tested to ensure correct operation. If you discover a problem with the operation of the machine or its safety components, do not operate it further until you have resolved the problem.

Note: Refer to **Troubleshooting** on **Page 38** for solutions to common problems that occur with all metal bandsaws. If you need additional help, contact our Tech Support at (360) 734-1540.

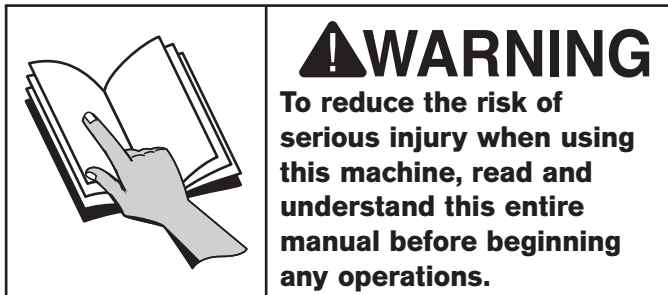

To test run your machine:

1. Read and follow the safety instructions at the beginning of the manual, take required safety precautions, and make sure the machine is set up and adjusted properly
2. Clear away all tools and objects used during assembly and preparation.
3. Make sure the blade is properly tensioned and the blade guides are positioned correctly (for detailed instructions, refer to **Blade Tensioning** on **Page 23**, and **Adjusting Blade Guides** on **Page 26**).
4. Connect the machine to the power source.
5. Push the ON button. The green motor light will illuminate and the motor will start.
6. Verify that the machine is operating correctly. When operating correctly, the machine runs smoothly with little or no vibration or rubbing noises.
7. Adjust the blade speed through the full range of operation. The speed should change as you make the adjustments.
8. Press the STOP button, the green motor light will go out, and the bandsaw will stop.
9. Turn the work lamp and the welding lamp **ON** and **OFF**.
10. Turn the grinder **ON** and **OFF**.

Note: For three phase-models, verify that the blade is moving downward toward the table. If so, the motor is running in the correct direction. Proceed to **Step 7**.

- If the blade is moving in the upward direction out of the table, stop the machine immediately. It is likely wired "out of phase." To correct this problem, disconnect the machine from the power source, and switch any two incoming power wires at the main terminal block (refer to **Figure 50** on **Page 48**).

Operation Overview

The purpose of the operation section is to familiarize you with the basic controls, terminology, capabilities, and adjustments that are necessary to use this machine.

To better understand the remaining parts of this section, please take a moment to read this overview.

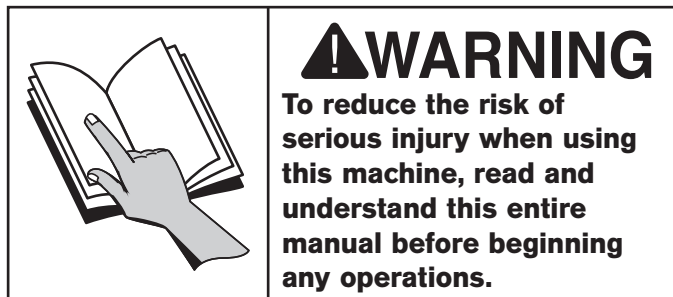

To complete a typical operation, the operator does the following:

1. Examines the workpiece to make sure it is suitable for cutting.
2. Checks to make sure blade tension is correct, and the blade guides are positioned correctly.
3. Marks the cut line on the workpiece.



4. Adjusts the upper blade guide height to approximately $\frac{1}{8}$ "– $\frac{1}{4}$ " above the workpiece for maximum blade support.
5. Puts on safety glasses, and rolls up sleeves or secures any clothing or hair that could get entangled with moving parts.

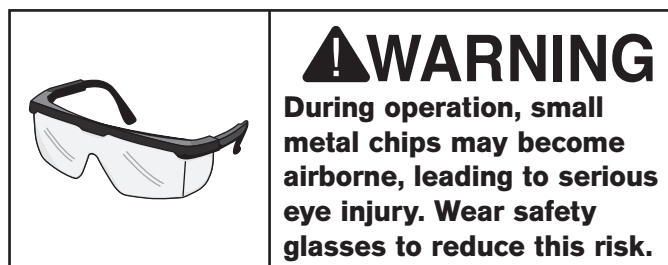
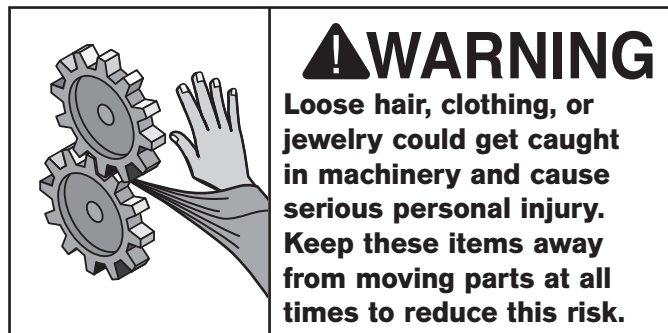

6. Turns the bandsaw **ON**, and adjusts blade speed for the type of material being cut.
7. Presses the workpiece against the blade, using light and even pressure and following the cut line with the blade.

Depending on the workpiece material, the operator may squirt a small amount of cutting fluid at the cutting area to keep it from overheating and smoking.

8. Turns the bandsaw **OFF**.

Controls

Refer to **Figures 6–8** and the following descriptions to become familiar with the basic controls of this machine.

- A. **Motor Light:** Lights when the ON button is pressed and there is power to the machine.
- B. **On Button:** Turns the bandsaw motor **ON**.
- C. **Off Button:** Turns the bandsaw motor **OFF**.
- D. **Clamping Pressure Dial:** Sets the correct amount of pressure for pressing the ends of the blades against each other.
- E. **Welding Clamp:** Holds a segment of the bandsaw blade to be welded.
- F. **Lock Lever:** Secures bandsaw blade for welding operations when rotated up.
- G. **Grinder Switch:** Turns grinding wheel **ON** and **OFF**.
- H. **Shear Lever:** Cuts the bandsaw blade.
- I. **Welding Button:** Activates the process of fusing the two blades together.
- J. **Annealing Button:** Heats up the blade joint, then allows it to cool in a gradual manner to establish weld strength.
- K. **Welder's Lamp Switch:** Illuminates welding station when turned **ON**.

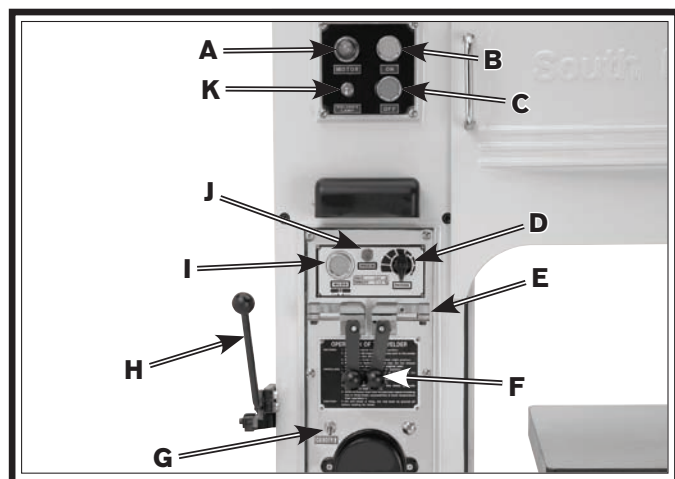

Figure 6. Front controls.

- L. **Variable Speed Handwheel:** Adjusts blade speed from 88 to 384 FPM.



Figure 7. Variable speed handwheel.

- M. **Blade Tensioning Handwheel:** Increases or decreases blade tension when rotated.
- N. **Guide Post Elevation Knob:** Raises or lowers the guide post and upper blade guide assembly.
- O. **Guide Post Lock Knob:** Secures the guide post and upper blade guide assembly in position.

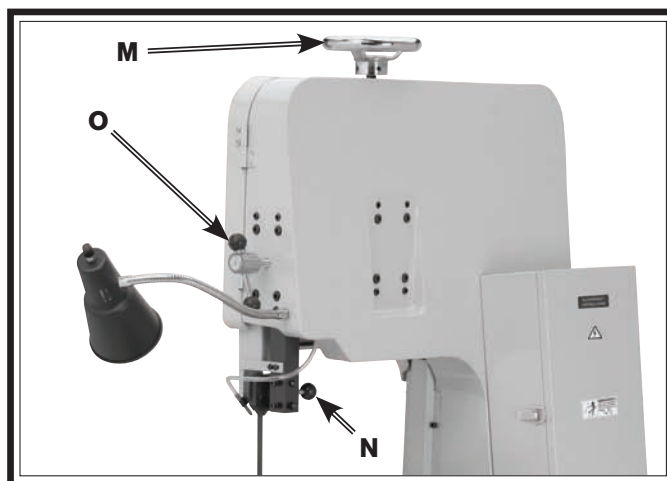

Figure 8. Blade controls.

Blade Selection

Selecting the right blade for the cut requires a knowledge of various blade characteristics.

Blade Terminology

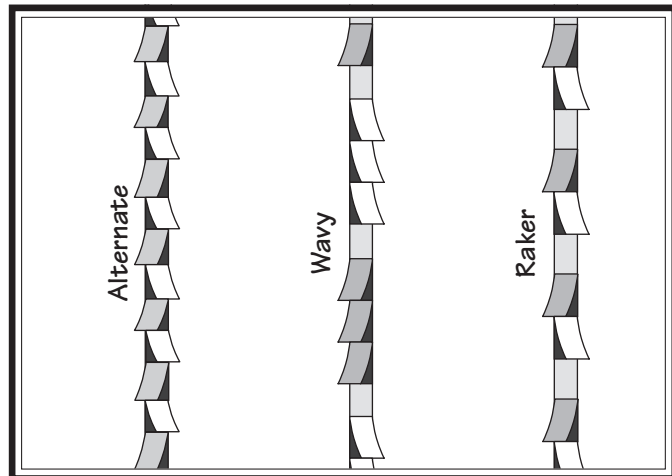

Figure 9. Bandsaw blade terminology.

- A. **Kerf:** The amount of material removed by the blade during cutting.
- B. **Tooth Set:** The amount each tooth is bent left or right from the blade.
- C. **Gauge:** The thickness of the blade.
- D. **Blade Width:** The widest point of the blade measured from the tip of the tooth to the back edge of the blade.
- E. **Tooth Rake:** The angle of the tooth face from a line perpendicular to the length of the blade.
- F. **Gullet Depth:** The distance from the tooth tip to the bottom of the curved area (gullet).
- G. **Tooth Pitch:** The distance between tooth tips.
- H. **Blade Back:** The distance between the bottom of the gullet and the back edge of the blade.
- I. **Blade Pitch or TPI:** The number of teeth per inch measured from gullet to gullet.

Blade Length

Measured by the blade circumference, blade lengths are usually unique to the brand of your bandsaw and the distance between the wheels.

Model	Blade Length Range
SB1021/SB1022.....	118¼"–119½"

Blade Width

Measured from the back of the blade to the tip of the blade tooth (the widest point), blade width is often the first consideration given to blade selection. Blade width dictates the largest and smallest curve that can be cut, as well as how accurately it can cut a straight line—generally the wider the blade, the straighter it will cut.

Model	Blade Width Range
SB1021/SB1022.....	⅛"–½"

Always pick the blade width that best suits your operation.

Curve Cutting: Use the chart in **Figure 10** to choose the correct blade for curve cutting. Determine the smallest radius curve that will be cut on your workpiece and use the corresponding blade width.

The list below shows the minimum radius that can be cut by each blade width.	
Width	Radius
⅛".....	⅛"
⅜".....	⅜"
¼".....	⅝"
⅜".....	1¼"
½".....	2½"

Figure 10. Blade width radii.

Tooth Set

Three common tooth sets are alternate, wavy, and raker (see **Figure 11**). Each removes material in a different manner to make the kerf in the workpiece.

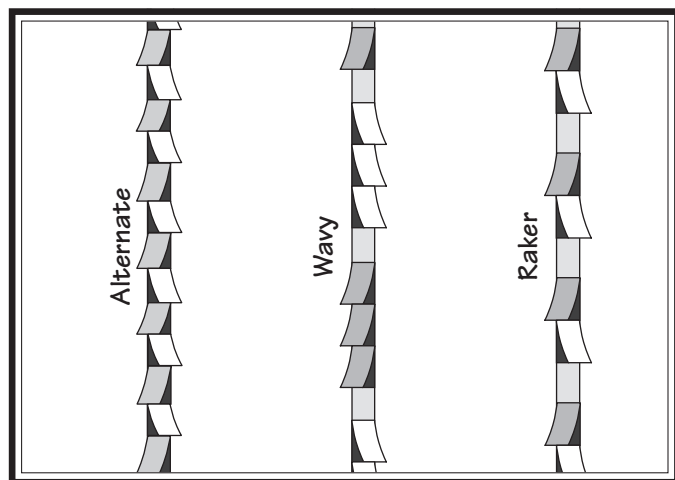

Figure 11. Bandsaw blade tooth sets.

Alternate: An all-purpose arrangement of bending the teeth evenly left and right of the blade. Generally used for milder metals.

Wavy: Generally three or more teeth in a group that are bent one way, followed by a non-set tooth, and then a group bent the other way. Recommended for straight cuts in thin metals or thin-wall tubing.

Raker: Three teeth in a recurring group—one bent left, next one bent right, and then a non-set tooth. The raker set is ideal for most contour cuts.

Tooth Type

The most common tooth types are described below and illustrated in **Figure 12**.

Standard or Raker: Equally spaced teeth set at a "0" rake angle. Recommended for all purpose use.

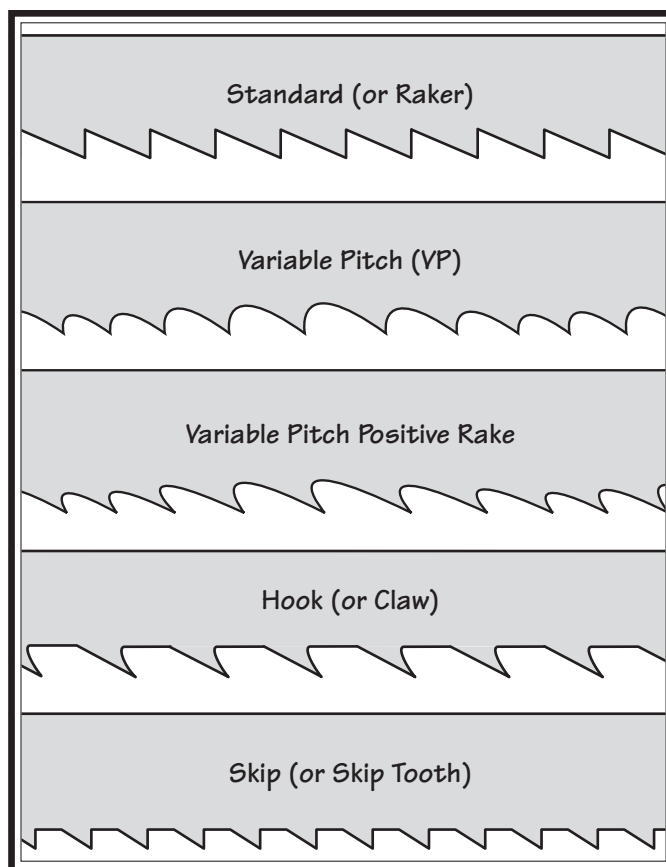

Figure 12. Bandsaw blade tooth types.

Variable Pitch (VP): Varying gullet depth and tooth spacing, a "0" rake angle, excellent chip removing capacity, and smooth cutting.

Variable Pitch with Positive Rake: Varying gullet depth and tooth spacing, a positive rake angle, better chip formation, and aggressive cutting.

Hook or Claw: Wide gullets (round or flat), equally spaced teeth, positive rake angle, and fast cut with good surface finish.

Skip or Skip Tooth: Wide, flat gullets, a "0" rake angle, equally spaced teeth, and recommended for non-ferrous materials.

Blade Pitch (TPI)

The chart below is a basic starting point for choosing teeth per inch (TPI) for variable pitch blades and standard raker set bi-metal blades/HSS blades. However, for exact specifications of bandsaw blades that are correct for your operation, contact the blade manufacturer.

To select the correct blade pitch:

1. Measure the material thickness. This measurement is the length of cut taken from where the tooth enters the workpiece, sweeps through, and exits the workpiece.
2. Refer to the "Material Width/Diameter" row of the blade selection chart in **Figure 13**, and read across to find the workpiece thickness you need to cut.

3. Refer to the "Material Shapes" row and find the shape of the material to be cut.
4. In the applicable row, read across to the right and find the box where the row and column intersect. Listed in the box is the minimum TPI recommended for the variable tooth pitch blades.
5. The "Cutting Speed Rate Recommendation" section of the chart offers guidelines for various metals, given in feet per minute (FPM). Choose the speed closest to the number shown in the chart.

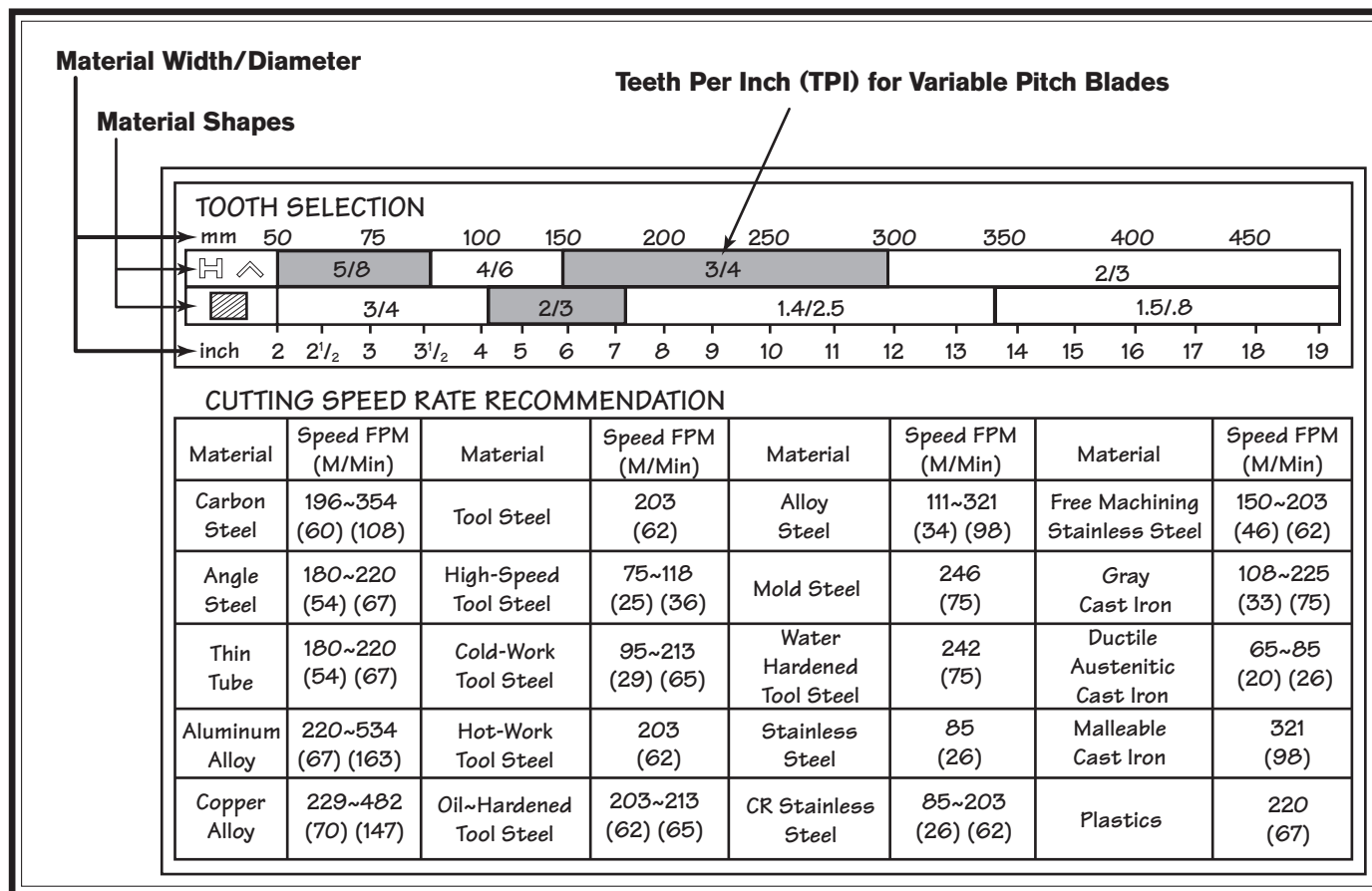
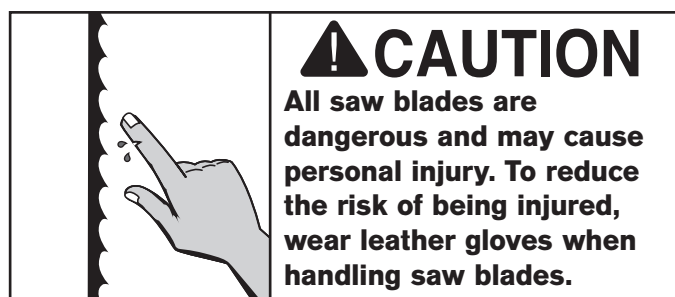
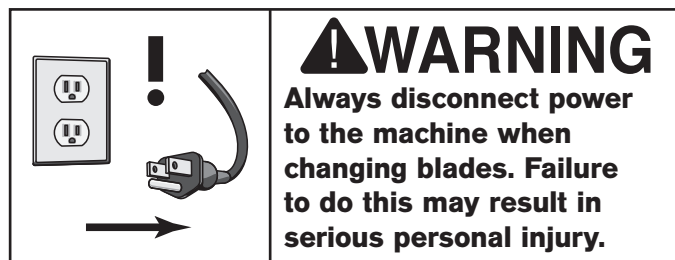

Figure 13. General guidelines for blade selection and speed chart.

Blade Changes



To replace the blade:

1. DISCONNECT BANDSAW FROM POWER!
2. Open the upper and lower wheel doors, release tension on the blade, and move the blade guides away from the blade.
3. Put on heavy gloves, then slide the blade off the upper and lower wheels, around the blade post, and through the table slit.
4. Install a new blade in reverse order.
5. Position the back edge of the blade so that it is next to, but not against, the flange of the top wheel (see **Figure 14**).

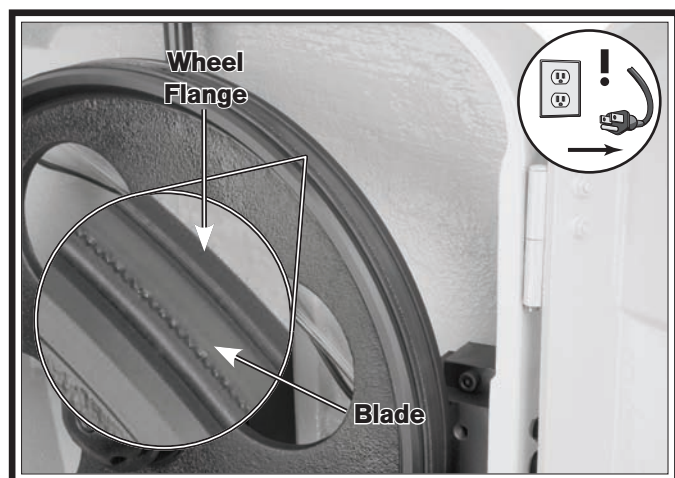

Figure 14. Back edge of blade next to wheel flange.

Note: Excessive blade contact with the wheel flange during operation could lead to blade and wheel damage.

6. Re-tension the blade (refer to the following **Blade Tensioning** section).
7. Rotate the top wheel clockwise by hand several times to make sure the blade tracks evenly without wandering across the wheel surface.

Note: If the blade wanders across the wheel and away from the flange, the wheel alignment may need to be adjusted. Refer to **Blade Tracking** on **Page 35** for detailed instructions.

8. Adjust the upper and lower blade guides (refer to **Adjusting Blade Guides** on **Page 26**).
9. Close and secure the upper and lower wheel doors.

Blade Tensioning

NOTICE

To prolong blade life, release the tension on the blade if the machine will be idle for an extended period of time.

Proper blade tension reduces the risk of blade breakage and improves cutting performance.

To correctly tension the blade:

1. DISCONNECT BANDSAW FROM POWER!
2. Turn the blade tension handwheel until you feel an average amount of resistance and the handwheel wants to stop. Then turn the handwheel an additional $\frac{1}{2}$ turn.

Blade Breakage

Many conditions may cause a bandsaw blade to break. Blade breakage is unavoidable, in some cases, since it is the natural result of the peculiar stresses that bandsaw blades must endure. Blade breakage is also due to avoidable circumstances. Avoidable blade breakage is most often the result of poor care or judgment on the part of the operator when mounting or adjusting the blade or support guides.

The most common causes of blade breakage are:

- Faulty alignment or adjustment of the blade guides.
- Forcing or twisting a wide blade around a tight radius.
- Feeding the workpiece too fast.
- Dull or damaged teeth.
- Over-tensioned blade.
- Top blade guide assembly set too high above the workpiece. Adjust the top blade guide assembly so that there is approximately $\frac{1}{8}$ "– $\frac{1}{4}$ " between the bottom of the assembly and the workpiece.

Note: The blade guide assembly can be lowered to within $2\frac{1}{2}$ " of the table surface.

- Using a blade with a lumpy or improperly finished braze or weld.
- Continuously running the bandsaw when not in use.
- Leaving the blade tensioned when not in use.
- Using the wrong blade pitch (TPI) for the workpiece thickness. The general rule of thumb is to have no fewer than two teeth in contact with the workpiece at all times during cutting.

Blade Care & Break-In

Blade Care

A bandsaw blade is a delicate piece of steel that is subjected to tremendous strain. A bandsaw blade will last longer if you give it fair treatment and always use the appropriate feed rate for your operation.

Be sure to select blades with the proper width, set, type, and pitch for each application. The wrong blade will produce unnecessary heat and have a shortened life.

A clean blade will perform much better than a dirty blade. Dirty or gummed up blades pass through the cutting material with much more resistance than clean blades. This extra resistance also causes unnecessary heat.

Blade Break-In

The tips and edges of a new blade are extremely sharp. Cutting at too fast of a feed rate can fracture these tips and edges, causing the blade to quickly become dull. Properly breaking-in a blade allows these sharp edges to wear properly without fracturing, thus keeping the blade sharp longer.

To properly break-in a new blade:

1. Choose the correct speed for the blade and material of the operation.
2. Reduce the feed pressure by half for the first 50–100 in² of material cut.
3. To avoid twisting the blade when cutting, adjust the feed pressure when the total width of the blade is in the cut.
4. Use the **Chip Inspection Chart** on **Page 25** to ensure that the optimal blade speed and feed rate are being used.

Blade Speed Chart

Use the blade speed chart in **Figure 15** to determine an appropriate speed to start with, then examine the chips once you start cutting to determine which way to adjust the speed or your feed rate.

Material Thickness	Dry Cutting Speed (FPM)		
	0 - 1/2"	1/2" - 1"	1" +
Alloy Steel	90	125	160
Aluminum	185	250	315
Brass (Soft)	375	500	625
Brass (Hard)	150	200	250
Bronze	150	200	250
Copper	185	250	315
Cast Iron	90	125	160
High Speed Steel	35	50	65
Low Carbon Steel	90	125	160
Medium Carbon Steel	75	100	125

Figure 15. Dry cutting blade speed chart.

Chip Inspection Chart

The best method for evaluating the cutting speed and feed rate for an operation is to inspect the chips created by the cut. Refer to the chip inspection chart below for chip inspection guidelines.









Chip Appearance	Chip Description	Chip Color	Blade Speed	Feed Pressure	Other Actions
	Thin & Curled	Silver	Good	Good	
	Hard, Thick & Short	Brown or Blue	Increase	Decrease	
	Hard, Strong & Thick	Brown or Blue	Increase	Decrease	
	Hard, Strong & Thick	Silver or Light Brown	Good	Decrease Slightly	Check Blade Pitch
	Hard & Thin	Silver	Increase	Decrease	Check Blade Pitch
	Straight & Thin	Silver	Good	Increase	
	Powdery	Silver	Decrease	Increase	
	Curled Tight & Thin	Silver	Good	Decrease	Check Blade Pitch

Figure 16. Chip inspection chart.

Positioning Guide Post Adjusting Blade Guides

The guide post assembly is used for two purposes: 1) To properly position the blade guard to protect the operator from the exposed blade between the workpiece and the upper wheel housing, and 2) to position the upper blade guides close to the workpiece for maximum blade support.

To properly position the guide post:

1. DISCONNECT BANDSAW FROM POWER!
2. Hold the guide post knob with one hand and loosen the guide post lock knob with the other (Figure 17).

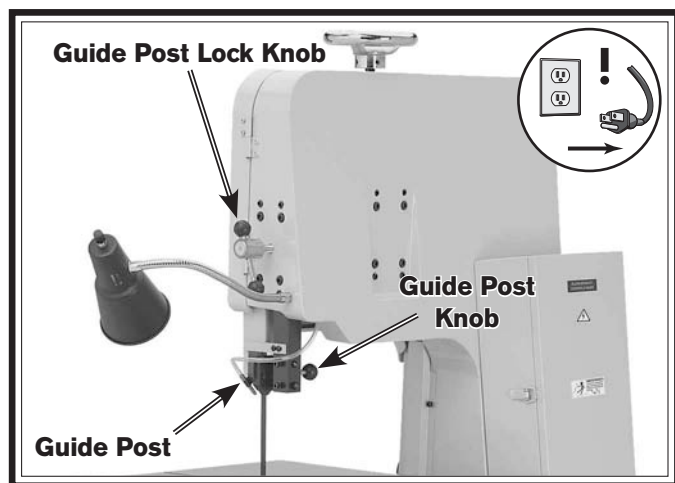
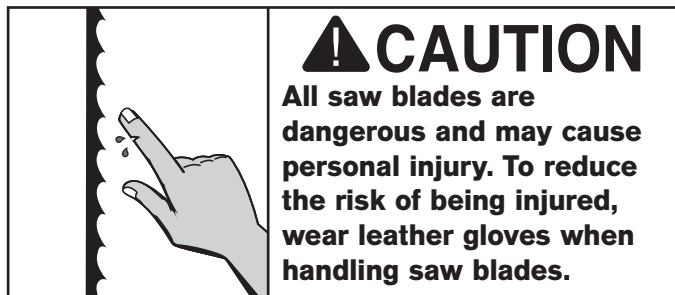

Figure 17. Guide post assembly.

3. Position the bottom of the upper blade guides approximately ¼" above the workpiece, then re-tighten the lock knob to secure the setting.



Adjusting Blade Guides

The blade guides provide side-to-side and rear support to keep the blade straight while cutting. The blade guides and the rear support have tungsten steel facing to reduce wear on the guides. Properly adjusted blade guides are essential to making accurate cuts.

If the blade guides rub the blade at either the top or bottom of the blade, follow the guide post alignment procedure on Page 36 for adjusting the guide post parallel with the blade.

To properly adjust the upper and lower blade guides:

1. DISCONNECT BANDSAW FROM POWER!
2. Make sure the bandsaw blade is properly tensioned (Page 23) and the guide post is locked.
3. Use a Phillips head screwdriver to remove the flange screws that secure the lower blade guide cover, then remove the cover to access the cap screws in the next step.
4. Use a 5mm hex wrench to loosen the cap screws that secure the blade guide bracket and blade support (see Figures 18–19).

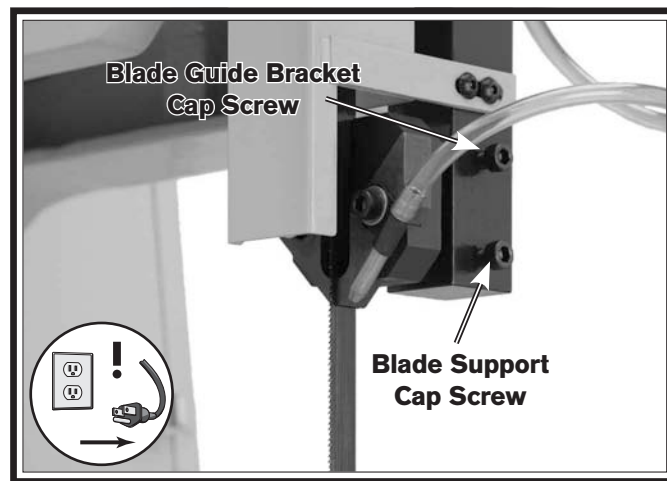

Figure 18. Upper blade guides and bracket.

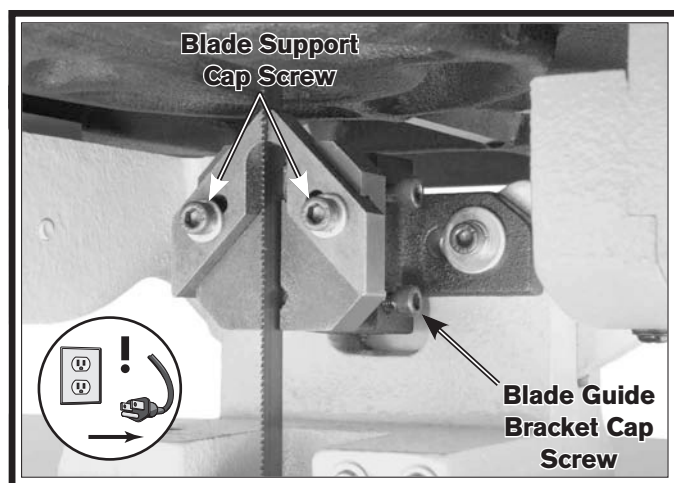

Figure 19. Lower blade guides and bracket.

5. Position the blade guides so that they are approximately $\frac{1}{16}$ " behind the tooth gullets (see **Figure 20**), then re-tighten the blade guide bracket cap screw.

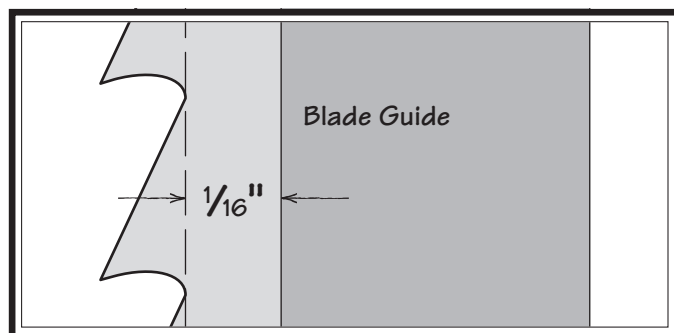

Figure 20. Blade guides positioned approximately $\frac{1}{16}$ " behind tooth gullets.

6. Slide the blade support (see **Figure 21**) up to, but not touching, the back of the blade, then re-tighten the blade support cap screw.

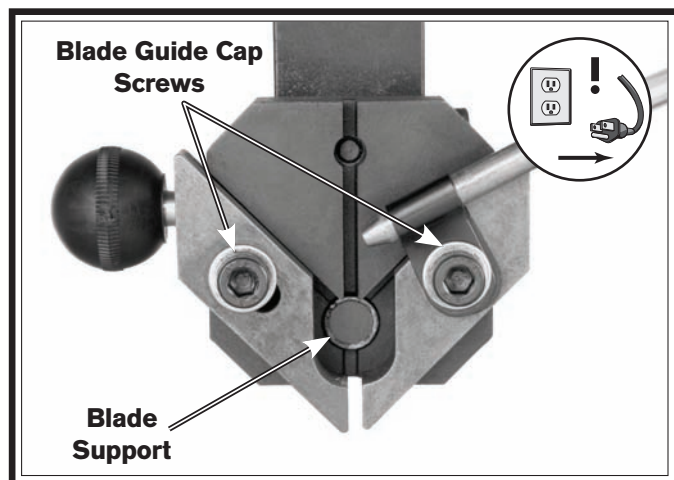

Figure 21. Blade guide assembly (upper assembly shown without blade for clarity).

Note: The blade guides must be adjusted far enough back so that they are behind the tooth gullets when the blade is deflected back against the blade support.

7. Use a 3mm hex wrench to loosen the button head cap screws that secure the upper blade guard, to allow access to the blade support cap screw in the next step.
8. Use a 5mm hex wrench to loosen the blade guide cap screws (see **Figure 21**).
9. Fold a crisp dollar bill in half and place it over the blade (between the blade guides and the blade), as shown in **Figure 22**.

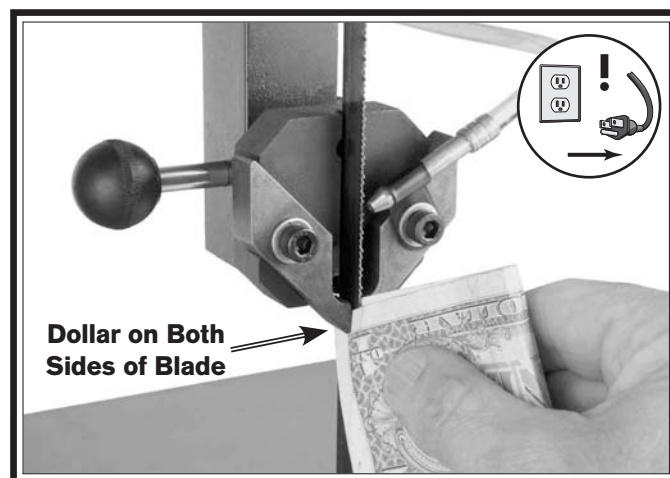

Figure 22. Using a dollar bill to set blade guide spacing (blade guide cover removed for clarity).

10. Lightly pinch the dollar bill against the blade with the blade guides, re-position the air nozzle if necessary, then re-tighten the blade guide cap screws.

Note: The goal is to position the blade guides as close as possible to the blade without touching it.

11. Secure the upper blade guide, then re-install the lower blade guard cover.

Tilting Table

The bandsaw table tilts 15° to the left and 15° to the right for basic cut angles, and 10° to the front and 10° to the back for feed angles. When used together, compound angled cuts can be made.

To tilt the table left or right:

1. DISCONNECT BANDSAW FROM POWER!
2. Use an 8mm wrench to loosen the two cap screws on the cut angle trunnion underneath the rear of the table (see **Figure 23**).

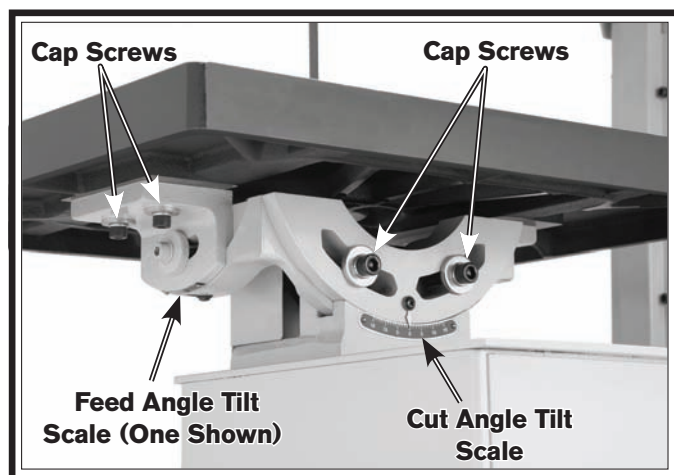

Figure 23. Table tilt adjustment controls.

3. Using the cut angle tilt scale, adjust the angle of the table for your operation, then re-tighten the cap screws.

To tilt the table forward or backward:

1. DISCONNECT BANDSAW FROM POWER!
2. Use a 6mm hex wrench to loosen both sets of cap screws on the two feed angle tilt scale brackets (see **Figure 23**).
3. Using the two scales, adjust the angle of the table for cutting a compound angle, then re-tighten the cap screws.

Blade Welding

Being able to quickly and safely weld a bandsaw blade comes in handy for the following situations:

- To re-join a blade that has been purposely cut for making an internal contour cut.
- To repair a broken blade that is still sharp and useful.
- To make a new blade from a roll of bulk blade banding.

Your metal cutting bandsaw is equipped with a blade welder that uses electrical current to heat and fuse the blade ends together. This process will leave the joint brittle, so an annealer is also included to give the blade strength and flexibility.

⚠ WARNING

The electric current that flows through the blade welder during operation could cause serious personal injury or death. To reduce the risk of electrocution or burns, never touch any metal part of the welding station or blade during welding or annealing.

To weld the ends of blade together:

1. Turn the bandsaw motor **OFF**.
2. Place the blade evenly against the back of the blade shear and firmly pull the handle down to square off the blade end (see **Figure 24**).



Figure 24. Using the blade shear to cut the blade.

Note: To make a proper blade weld, the ends of the blade must be evenly butted together during the welding process. If necessary, use the grinder to square up the ends or remove any teeth that are in the welding zone (see **Figs. 25–26**).

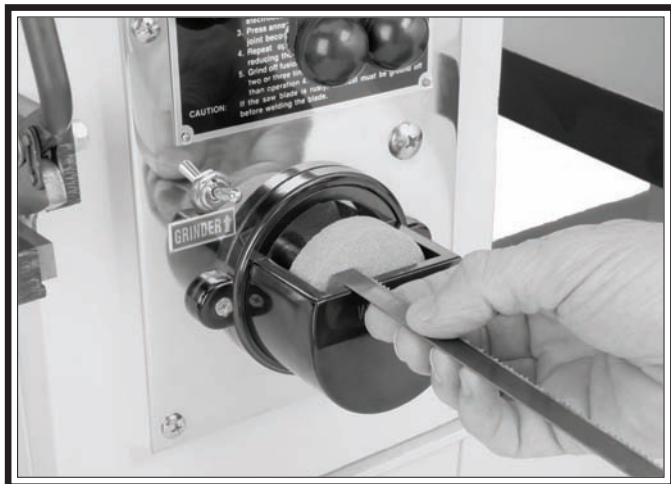

Figure 25. Using the grinder to square up the blade end.

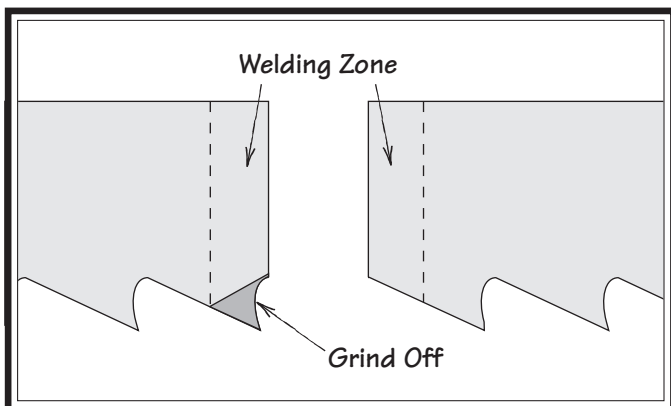

Figure 26. Blade ends and welding zone.

NOTICE

For good metal-to-metal contact between the welding clamps and the blade, make sure the blade material and the clamps are free from any debris or flash before each use.

- To ensure correct electrical continuity while welding, use mineral spirits to clean off all oil and debris from the first 6" of each end of the blade.
- Set the clamping pressure to 0" with the clamping pressure dial (**Figure 29**).

- Loosen the welding clamps by pulling the lock levers down.
- Position the back of one blade end evenly against the back of the welding clamp so that the end is midway between the two clamps, then rotate the lock lever as far up as possible to hold the blade end in place (see **Figure 27**).

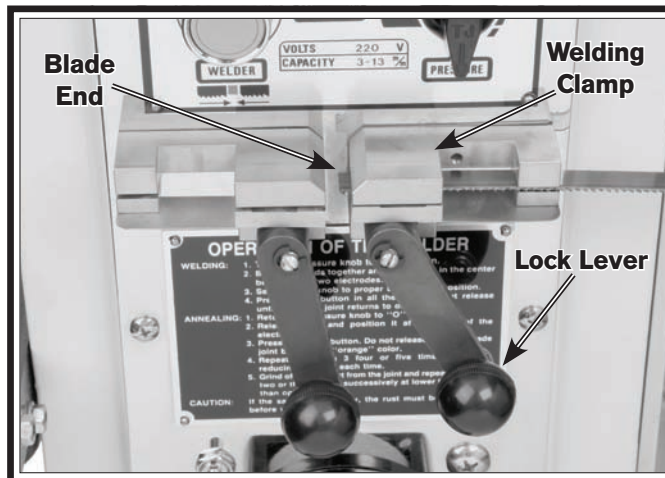

Figure 27. Blade end properly position in welding clamp and locked in place.

- Use the illustration in **Figure 28** and set the correct clamping pressure setting for width of the blade.

Note: The clamping pressure presses the blade ends together to help form a strong weld. The pressure scale is an approximation only. If you have difficulty getting satisfactory welds, experiment by increasing or decreasing this pressure.

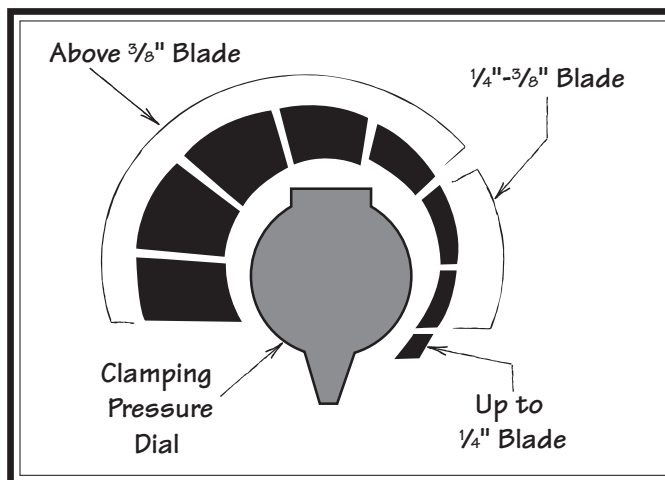

Figure 28. Blade clamping settings.

8. Place the other blade end in the opposite welding clamp and position it so that it evenly butts up against the opposing blade end, then lock it in place by rotating the lock lever all the way up, as shown in **Figure 29**.

Note: For a good blade weld, it is critical that the blade ends evenly butt up against each other without overlap, gaps, or misalignment.

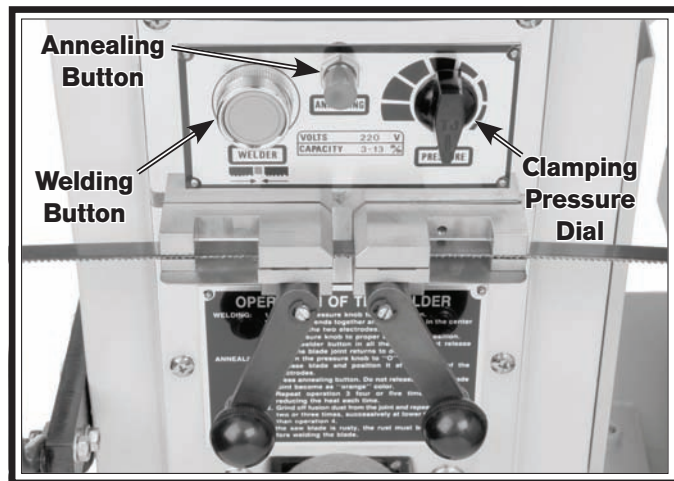

Figure 29. Blade ends in correct position for welding.

⚠ WARNING

Light generated during the welding process could cause serious eye damage. To reduce your risk, always use eye protection approved for welding when using the blade welder.

⚠ CAUTION

Burning sparks may be thrown in all directions while welding. Protect yourself from injury by not welding near flammables and wearing spark-resistant clothing/gloves. Keep fire extinguishing equipment readily available.

9. Press and release the welding button. The blade ends will be welded together.
10. Rotate the lock levers down to release the welding clamps, then rotate the clamping pressure dial to "0".

11. Inspect the weld. The welded joint should be even across the width of the blade with no gaps (see **Figure 30**).

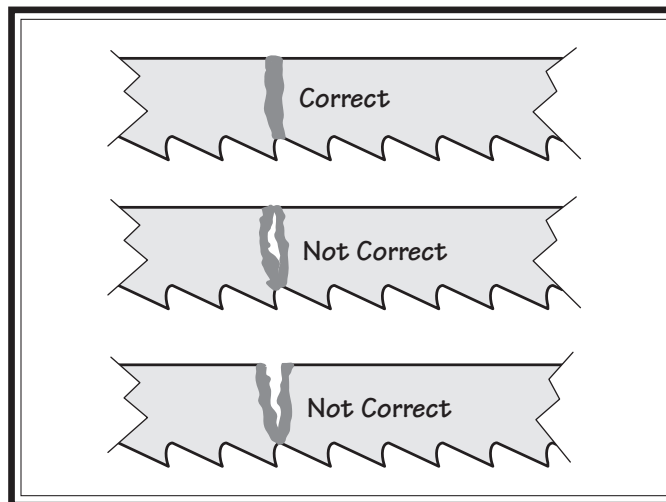

Figure 30. Blade welded joint examples.

- If the weld is satisfactory, continue to **Step 12**.
- If the weld is NOT satisfactory, begin again at **Step 2**.

12. Place the blade in the welding clamps with the weld centered between the clamps and re-tighten the lock levers.

Note: The welding operation leaves the blade joint brittle. Annealing allows the material to cool in gradual manner, giving the weld strength and flexibility. When annealing, the blade is heated until it turns a specific color that is determined by the blade material. The annealing process is unsuccessful (blade breaks easily) if the weld is not heated enough or if it is heated too much. For best results, contact the blade manufacturer for the proper annealing color.

- 13.** Press and hold the annealing button until the weld zone turns the appropriate color, then release the button.

Note: If you cannot get the proper annealing color from the blade manufacturer, use the recommendations below as a baseline and experiment from there.

- Carbon Steel Dull Cherry Red
- Carbon Steel Hard Back Blue
- Bi-Metal Orange
- High Speed Steel Dull Cherry Red

- 14.** Repeat **Step 13** three to four more times, allowing the weld to cool for about 30 seconds between each repetition. Each time reduce the amount of time you press the anneal button, to reduce the amount of heat successively.
- 15.** Allow the blade to cool, then re-inspect the weld.
- 16.** Grind away the weld bead on the top and bottom of the joint so that the blade is flat and will run smoothly on the wheels and between the blade guides.

Note: Make sure not to grind the teeth or blade body, or overheat the blade during grinding—this will weaken the blade. A small amount of ticking is acceptable during cutting operations.

- 17.** Re-clamp the blade in the welding clamps with the joint centered, then repeat the annealing process twice more. Each time gradually reduce the amount of time you anneal the weld.
- 18.** Test the strength and flexibility of the weld by bending the blade in an arc similar to that of the bandsaw wheels. The blade should bend in a smooth circular, rounded shape—rather than a pointed fold (see **Figure 31**).

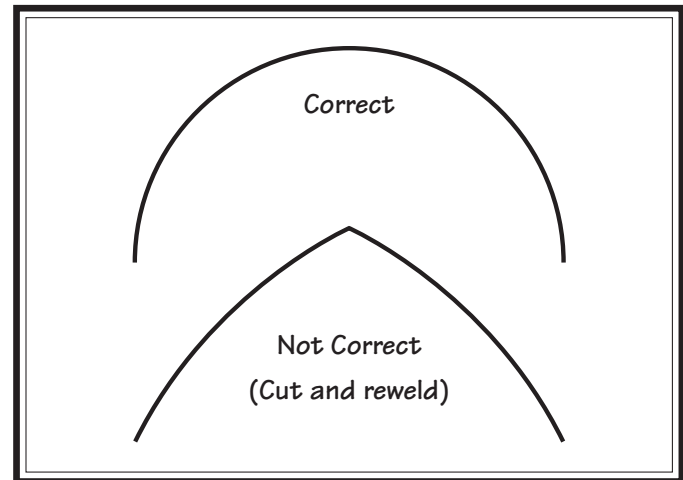
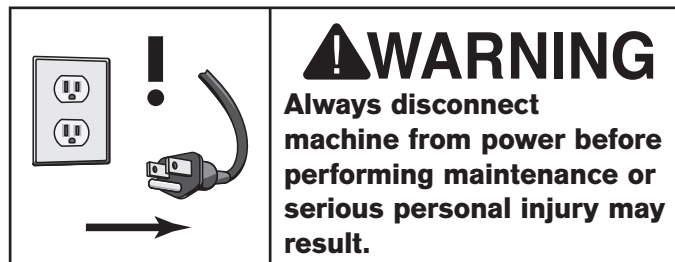

Figure 31. Correct blade weld bend for strength and flexibility.

Maintenance Schedule



For optimum performance from your machine, follow this maintenance schedule and refer to any specific instructions given in this section.

Daily:

- Check/correct loose mounting bolts.
- Check/correct damaged or dull saw blade.
- Check/correct worn or damaged wires.
- Clean/protect table.
- Clean metal chips from upper and lower wheel areas, and empty the chip chute.
- Correct any other unsafe condition.

Monthly:

- Check for V-belt tension, damage, or wear.
- Lubricate tension leadscrews and guide post rack.
- Remove the blade and clean the wheels.

Yearly:

- Open rear lower cover, inspect belts, and tighten all fasteners (see **Page 34**).

Cleaning

Use a brush and a shop vacuum to remove chips and other debris from the machine. Keep the table rust-free with regular applications of a high quality anti-rust product.

Once a month, remove the blade and thoroughly clean all metal chips or oil from the wheel surfaces. Redress the rubber tires if they become glazed.

When cleaning the wheel areas, empty and clean the chip chute and brush (**Figure 32**).

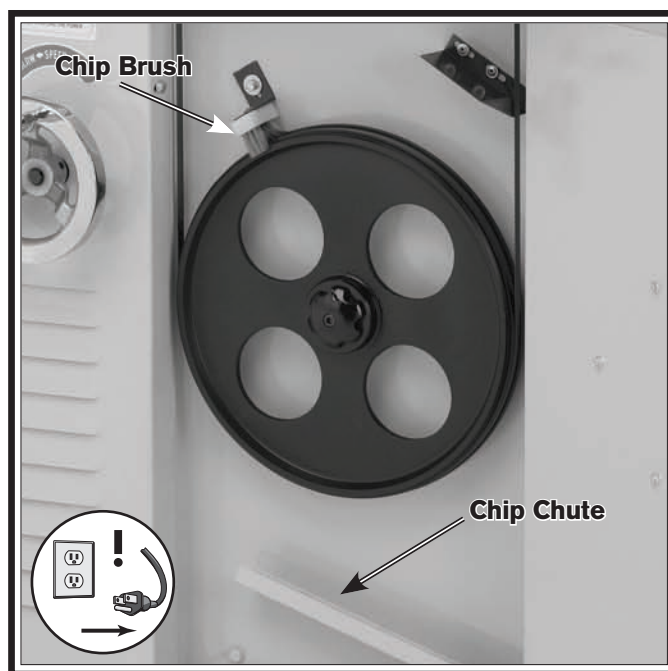

Figure 32. Lower wheel and chip chute.

Dressing Grinding Wheel

Periodically dress the grinding wheel to square it up and renew the abrasive surface. Dressing is done in the same manner as a typical grinding operation but using a diamond-tipped dressing tool (see **Figure 33**).

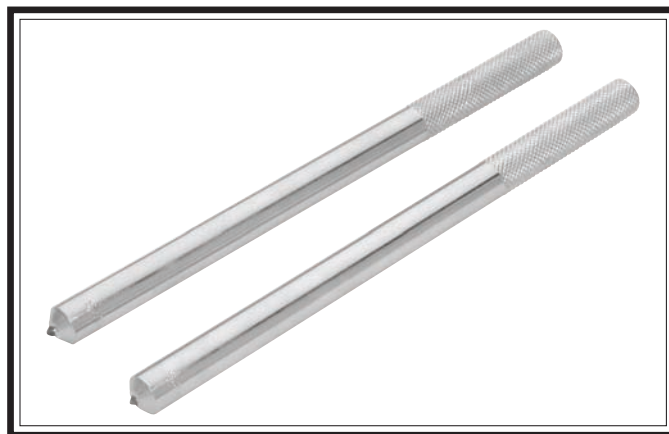

Figure 33. Example of diamond dressing tools.

Lubrication

The bearings on your bandsaw are factory lubricated and sealed. Leave them alone unless they need to be replaced.

When needed, brush a light coat of multi-purpose grease on the blade tension leadscrew (Figure 34).



Figure 34. Upper wheel leadscrew lubrication.

Use multi-purpose grease and a light machine oil where in Figure 35.

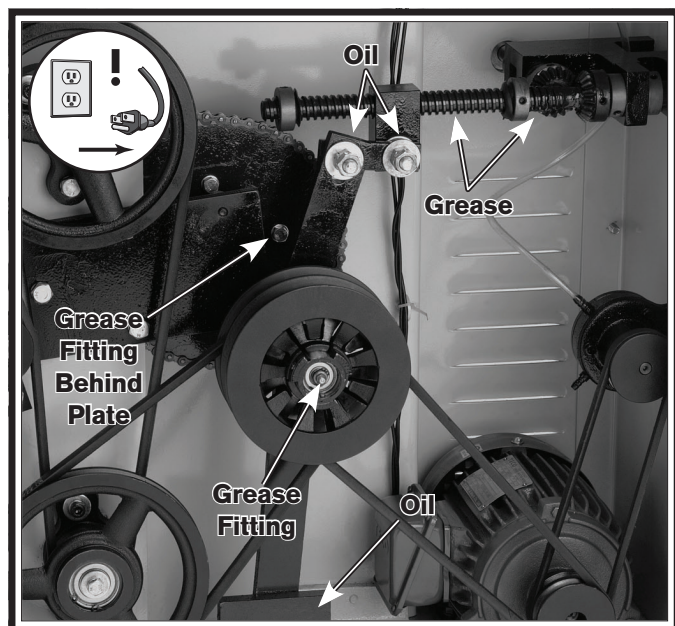

Figure 35. System lubrication points.

If the table becomes difficult to tilt, position it so that you can brush a thin coat of multi-purpose grease on the trunnion sliding surfaces (see Figure 36), then move back-and-forth to distribute.

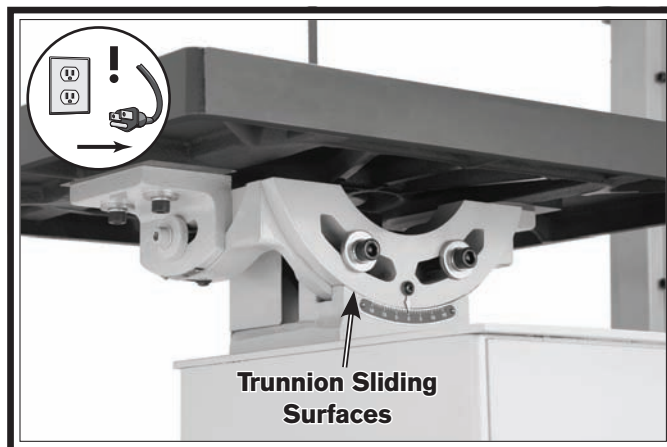

Figure 36. Trunnion lubrication.

The sliding surfaces on the guide post may occasionally need to be lubricated with a light machine oil if the movement becomes stiff.

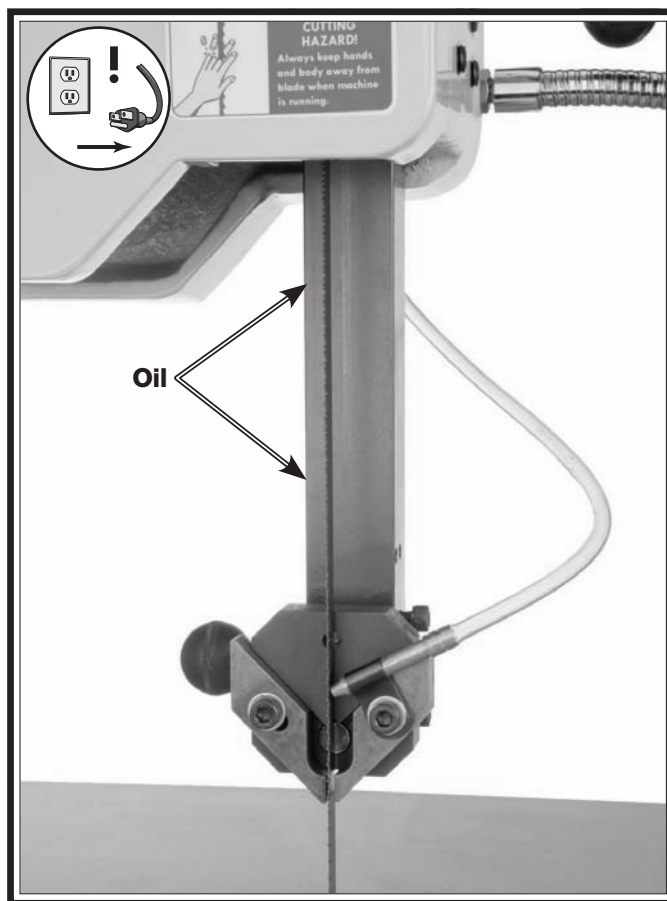

Figure 37. Guide post lubrication.

V-Belts

To ensure optimum power transfer from the motor to the blade, the V-belts must be in good condition and operate under proper tension.

Check V-belt tension at least every three months—more often if the bandsaw is used daily. V-belts stretch with use and must be periodically re-tensioned. Replace the V-belts if they are cracked, frayed, or badly worn. Refer to **Figure 38** to identify V-belt locations.

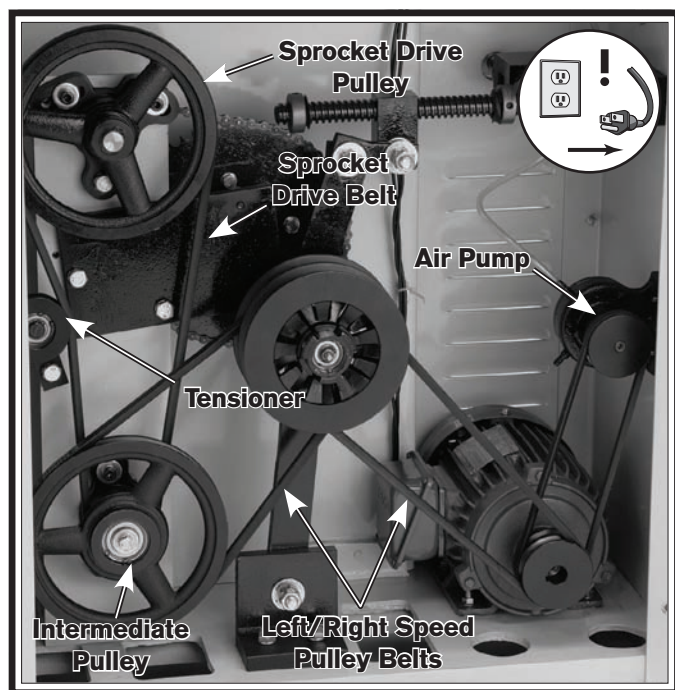

Figure 38. System belt and pulley layout.

To check/tension/replace the V-belts:

1. DISCONNECT BANDSAW FROM POWER!
2. Remove the rear motor access panel.
3. Push the center of each V-belt with moderate force. When tensioned correctly, there should be approximately $\frac{3}{16}$ " of deflection. DO NOT overtighten the belts or the bearings will wear prematurely.

Speed Hub Belts

Rotate the speed handle left or right until the belts are loose. Roll the belts off the pulleys to replace them. (If you get them mixed up when replacing, the belt on the left is the larger of the two.)

Note: When the machine is started, the belts will automatically adjust to the correct tension.

Sprocket Drive Belt

Use a 17mm wrench and loosen the tensioner hex bolt. Next use a 6mm hex wrench to loosen the three intermediate pulley retaining cap screws so the belt is loose. Replace the sprocket drive belt. Re-tighten the intermediate hub and adjust the tensioner hub to tension the new belt.

Air Pump Belt

Use a 10mm wrench to loosen the pump mounting bolts, replace the belt and tension it by positioning the air pump, then tighten the mounting bolts.

Note: Make sure that when tightened, the pump pulley is aligned with the motor drive pulley.

Dressing Rubber Tires

As the bandsaw ages, the rubber tires on the wheel may need to be redressed if they become hardened or glazed over. Dressing the rubber tires improves blade tracking and reduces vibration/blade lead.

If the rubber tires become too worn, then blade tracking will become extremely difficult. At that point, redressing will no longer be effective, and the rubber tires must be replaced.

To redress the rubber tires:

1. DISCONNECT BANDSAW FROM POWER!
2. Put on heavy gloves and remove the blade.
3. Use a brush and shop vacuum to clean any chips from the rubber tires.
4. Hold a piece of 100-grit sandpaper against the rubber tire and rotate the wheel by hand. Only redress the rubber enough to expose a fresh rubber surface.
 - a. Check surface area of tire to ensure a uniformly sanded surface.

Blade Tracking

A blade that is tracking correctly runs cooler, reduces wear-and-tear on the machine, and increases cutting performance. When tracking correctly, the blade rides next to, but not against, the wheel flange. The tracking is controlled by adjusting the upper wheel.

To adjust the upper wheel for blade tracking:

1. DISCONNECT BANDSAW FROM POWER!
2. Make sure the blade guides are adjusted away from the blade so they will not interfere with the change of blade position.
3. Ensure that the blade is correctly tensioned.
4. Using a 6mm hex wrench, loosen the four locking cap screws (**Figure 39**).

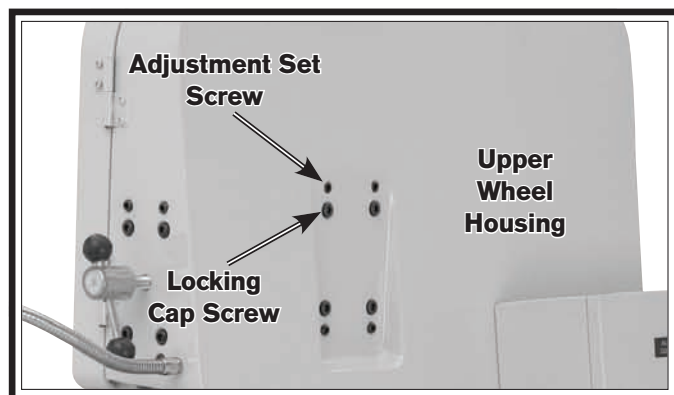

Figure 39. Wheel alignment.

5. Use a 5mm hex wrench to adjust the four set screws (**Figure 39**) to tilt the upper wheel in or out and bring blade tracking back to normal. Only adjust each screw in small increments.
6. Rotate the upper wheel by hand a couple times in the normal direction of rotation. Verify that the blade tracks next to, but not against, the wheel flange. Repeat **Steps 5-6** if necessary until the blade tracks correctly.
7. Tighten the locking cap screws and recheck the tracking to make sure it did not change. If it did, repeat **Steps 4-7**.
8. Adjust the blade guides back to their correct position.

Table Calibration

To ensure the accuracy of angle cuts and compound angle cuts, the scale pointers must point to zero when the table is perpendicular or 90° to the blade.

To calibrate the table to zero:

1. DISCONNECT BANDSAW FROM POWER!
2. Make sure the blade tracking and tension are set correctly.
3. Using a 6mm hex wrench, loosen the trunnion cap screws (**Figure 40**).

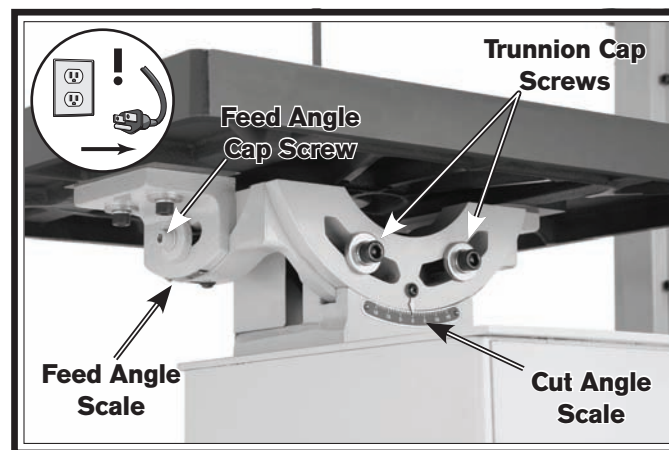

Figure 40. Location of table scales.

4. Place a machinist's square on the table and against the side of the blade, as shown in **Figure 41**.

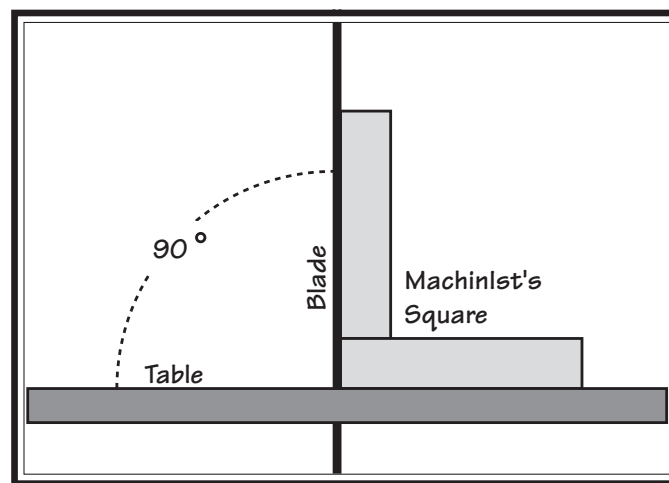

Figure 41. Checking that table is perpendicular to blade.

5. Tilt the table until the blade and table top are perpendicular, then tighten the trunnion cap screws.
6. Loosen the scale pointer for the cut angle scale (on the trunnion) and point it to zero.
7. Loosen the feed angle cap screw and place the machinist's square against the back of the blade.
8. Position the table perpendicular to the blade.
9. Tighten the feed angle cap screws.
10. Loosen the pointer for the feed angle scale, and point it to zero. The table and blade are now calibrated.

Guide Post Alignment

If the blade guide post does not raise and lower exactly parallel with the blade, the clearances between the blade guides and blade will change as the guide post is moved, causing rubbing, wear, and blade deflection. Blade guide clearance must stay the same when the guide post is raised and lowered along its full length of travel.

To align the guide post:

1. DISCONNECT BANDSAW FROM POWER!
2. Make sure the blade tracking and tension are set correctly.
3. Lower the blade guide post to the bottom of its travel and lock it in place.
4. Adjust the blade guides as described on **Page 26**.
5. Unlock the post just enough to allow it to slide, move it all the way up, then examine the clearances between the blade and blade guides to see if they changed.

If these clearances changed beyond your acceptable tolerances, the blade guide receiver (**Figure 42**) can be adjusted to fix this condition.



Figure 42. Guide post system.

6. Using a 6mm hex wrench, loosen the four guide post receiver cap screws (**Figure 43**).

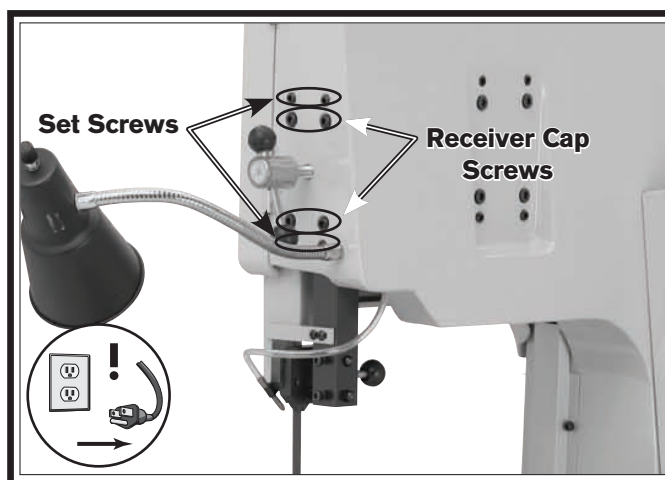

Figure 43. Guide post alignment controls.

7. Using a 5mm hex wrench, adjust the four set screws to tilt the blade guide receiver in the required direction.
8. Tighten the cap screws and recheck blade guide clearance along the guide post path of travel.
9. Repeat this procedure if necessary to fine-tune the guide post travel to acceptable tolerances.

Pinion Gear Backlash

During the life of the machine, the variable speed handwheel may develop extra backlash due to normal wear of the pinion gears. If this lash becomes unacceptable, use this procedure to reduce the backlash.

To reduce the pinion gear backlash:

1. DISCONNECT BANDSAW FROM POWER!
2. Remove the rear lower access panel, and use a 4mm hex wrench to loosen both pinion gear locking set screws (**Figure 44**) just enough to adjust the pinion gears.

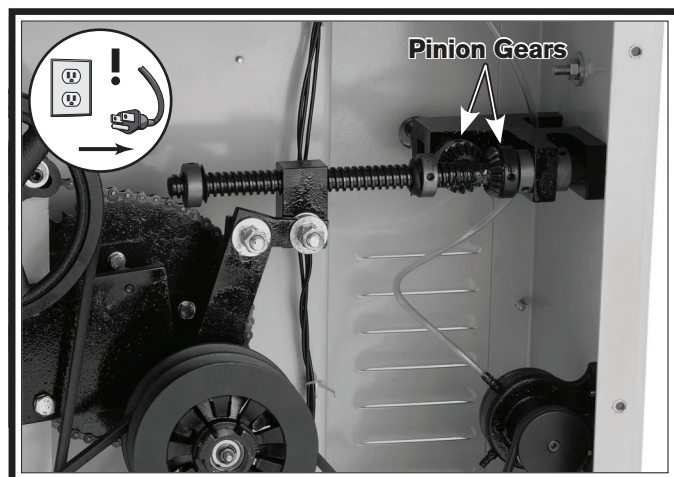

Figure 44. Location of pinion gears.

3. Slide the pinions closer together, and tighten the set screws. If excess backlash still exists, refer to the **Leadscrew End Play** section, then proceed to **Step 4**.

Note: Make sure that the set screws remain aligned with the flats on the shaft. If one or both setscrews do not return to their original depth in the pinion gear after tightening, the alignment has probably been lost and needs to be corrected.

4. Clean and grease the pinion gears and the leadscrew, then reinstall the access panel.

Leadscrew End Play

If you notice that the leadscrew has end play and the variable speed handwheel has excess backlash after the pinion gear lash has been set, you can adjust the lead screw collars as an additional measure to reduce the backlash.

To adjust the lead screw collars to reduce backlash:

1. DISCONNECT BANDSAW FROM POWER!
2. Remove the rear lower access panel, and use a 4mm hex wrench to loosen both collar locking set screws just enough to adjust the collars (**Figure 45**).

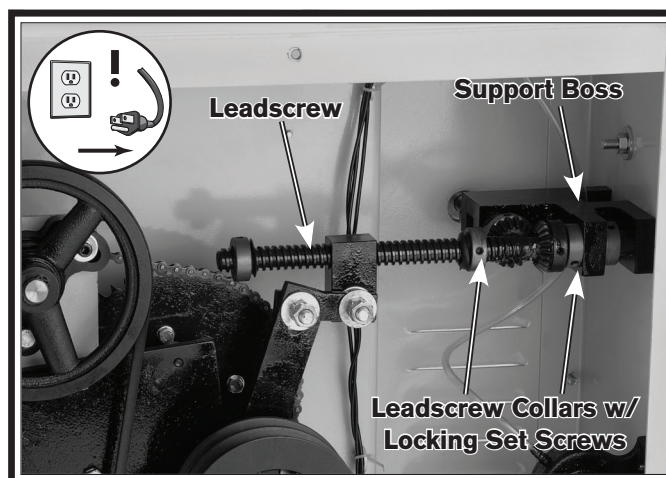

Figure 45. Leadscrew adjustment locations.

3. Slide the right-hand leadscrew collar against the support boss and tighten the set screws. If excess backlash still exists at the handwheel, you may have to readjust the pinion gear lash, replace the leadscrew half nut, or replace worn bolts or linkage (**Figure 46**).

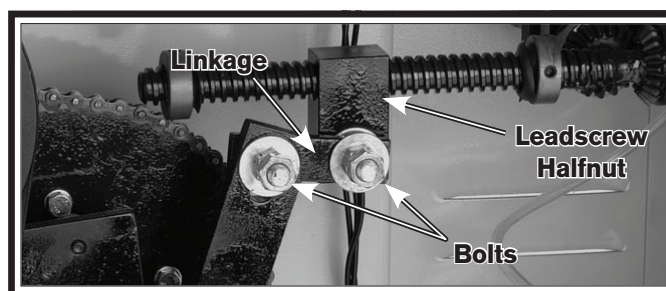

Figure 46. Linkage location and parts.

4. Reinstall the access panel.

Troubleshooting

If you need replacement parts, or if you are unsure how to do any of the solutions given here, feel free to call us at (360) 734-1540.

Symptom	Possible Cause	Possible Solution
Machine does not start.	<ol style="list-style-type: none"> 1. Power supply switched off/has incorrect voltage. 2. Blown fuse/tripped circuit breaker at main panel. 3. Plug or receptacle is corroded or mis-wired. 4. Thermal overload relay has tripped. 5. Break or short in wiring; or loose connections. 6. Motor ON/OFF switch at fault. 7. Motor connection wired incorrectly. 8. Start capacitor blown or at fault. 9. Contactor not energized/has poor contacts. 10. Centrifugal switch at fault. 11. Motor at fault. 	<ol style="list-style-type: none"> 1. Switch power supply on/verify voltage. 2. Correct the cause of overload, then reset/replace fuse or breaker. 3. Clean/retighten contacts; correct the wiring. 4. Allow relay/motor to cool. If necessary, press reset button inside switch. 5. Trace/replace broken or corroded wires; fix loose connections. 6. Replace switch. 7. Wire motor correctly (refer to inside junction box cover or manual). 8. Replace start capacitor. 9. Test all legs for power, test field coil and replace if at fault. 10. Adjust/replace centrifugal switch. 11. Test for shorted windings, bad bearings and repair or replace.
Main motor chatters during startup or during operation.	<ol style="list-style-type: none"> 1. Extension cord (if used) is causing voltage drop. 2. Phase converter (if used) wild wire connected wrong. 3. Power supply has incorrect voltage on one or more legs. 	<ol style="list-style-type: none"> 1. Move machine closer to the power source or use a larger gauge or shorter extension cord. 2. Connect wild wire to the machine power supply terminal that is not part of the contactor field coil power supply circuit. 3. Contact your power company to fix the power supply.
Machine operates in reverse.	<ol style="list-style-type: none"> 1. Power connections wired out of phase (SB1022 only). 	<ol style="list-style-type: none"> 1. Swap two power incoming power leads (see Page 47).
Machine has excessive vibration or noise.	<ol style="list-style-type: none"> 1. Motor fan rubbing on fan cover. 2. Motor or table is loose. 3. V-belt(s) loose. 4. Guide post lock lever is loose. 5. Machine incorrectly mounted on floor. 6. V-belt(s) worn or damaged. 7. Pulley loose or not in alignment; shaft bent. 8. Centrifugal switch out of adjustment; at fault (SB1021 only) 9. Motor bearings worn or damaged. 10. Phase converter (if used) wild wire incorrectly connected (SB1022 only). 	<ol style="list-style-type: none"> 1. Fix/replace fan cover; replace loose or damaged fan. 2. Tighten any loose fasteners. 3. Tighten V-belt(s). 4. Tighten the lock lever. 5. Level/shim base; tighten/adjust mounting hardware or feet. 6. Replace V-belt(s). Use link belts if possible. 7. Replace worn pulley, key, and shaft, and realign. 8. Adjust/replace centrifugal switch. 9. Replace motor bearings or replace motor. 10. Connect wild wire to correct leg (must avoid transformer or sensitive electronics).

Symptom	Possible Cause	Possible Solution
Machine stalls or slows when operating.	<ol style="list-style-type: none"> 1. Too much pressure when feeding workpiece. 2. Motor is wired out of phase (SB1022 only). 3. Workpiece is warped and binding blade. 4. Blade is not correct for material being cut. 5. Belt(s) slipping. 6. Motor overheated. 7. Run capacitor at fault (SB1021 only). 8. Pulley or sprocket slipping on shaft. 9. Motor connection wired incorrectly. 10. Contactor has poor contacts. 11. Centrifugal switch at fault (SB1021 only). 12. Motor at fault. 	<ol style="list-style-type: none"> 1. Reduce pressure when feeding workpiece. 2. Swap two power incoming power leads (see Page 47). 3. Fabricate a jig for better workpiece control. 4. Use the correct blade for the operation. Refer to Blade Selection section beginning on Page 20. 5. Tension/replace belt(s); ensure pulleys are aligned. 6. Let cool, clean motor, and reduce workload. 7. Test/repair/replace. 8. Replace pulley and key or set screw. Replace shaft if worn. 9. Review wiring diagram on motor cover; correct wire connections. 10. Test all legs for power, test field coil and replace if at fault. 11. Adjust/replace centrifugal switch if available. 12. Test for shorted windings, bad bearings and repair or replace.
Handwheel has excessive backlash, endplay, binds, or is difficult to move.	<ol style="list-style-type: none"> 1. Leadscrew is dirty or lacks proper lubrication. 2. Pinion gears out of adjustment. 3. Bearing or leadscrew collar is worn or loose. 4. Linkage bolts, pins, and holes are loose or worn. 5. Leadscrew or leadscrew nut worn. 	<ol style="list-style-type: none"> 1. Clean and lubricate the leadscrew (see Page 33). 2. Re-adjust pinion gears to reduce backlash (see Page 37). 3. Replace bearing or readjust leadscrew collar (see Page 37). 4. Replace linkage bolts, pins, and re-bush any worn pin holes. 5. Replace leadscrew or leadscrew nut.
Cuts are not square or the intended angle is incorrect.	<ol style="list-style-type: none"> 1. Pointer or scale not calibrated or loose table. 2. Table guide post is loose or out of alignment. 	<ol style="list-style-type: none"> 1. Zero table to blade and realign scale pointers (see Page 35). Tighten any loose fasteners. 2. Tighten any loose hardware or lock levers. Align the guide post (see Page 36).
Grinder does not work.	<ol style="list-style-type: none"> 1. Wiring or ON/OFF switch at fault 2. Motor at fault. 	<ol style="list-style-type: none"> 1. Repair wiring or replace grinder switch. 2. Replace motor.
Work lamp or welding lamp does not work	<ol style="list-style-type: none"> 1. Bulb, wiring, or switch at fault. 2. Transformer is at fault. 	<ol style="list-style-type: none"> 1. Replace bulb, repair wiring, replace switch. 2. Replace transformer.
Welder is inoperative or welds poorly.	<ol style="list-style-type: none"> 1. Operator error. 2. Wiring or welding switch at fault. 3. Welder transformer at fault. 	<ol style="list-style-type: none"> 1. Use welder as outlined in operations section and practice on scrap blades (see Page 28). 2. Repair wiring or replace welding switch. 3. Replace welder transformer.

Symptom	Possible Cause	Possible Solution
Machine or blade bogs down in the cut.	<ol style="list-style-type: none"> 1. Excessive load on the blade. 2. V-belts loose; belt squeals at times. 3. V-belts worn and slips. 4. Blade is loading up. 5. Blade is dull, wanders, and gets pinched in the cut. 6. Blade is dull. 7. The blade TPI is too coarse for the thin workpiece. 8. Blade is loose. 9. Material requires cutting fluid. 10. The run capacitor is at fault (SB1021 only). 	<ol style="list-style-type: none"> 1. Reduce feed rate or increase blade speed 2. Tighten V-belts. 3. Replace V-belts. 4. Install a blade with more suitable TPI or different style of teeth. 5. Replace blade, adjust guides and tracking. 6. Replace blade. 7. Use a blade with at least 2 teeth contacting the material at all times. 8. Clean wheels and increase blade tension. 9. Use applicable cutting fluid. 10. Replace the run capacitor.
Blade tracks incorrectly, or comes off wheels.	<ol style="list-style-type: none"> 1. Feed rate is too fast. 2. Blade is not tracking correctly. 3. Blade is bell-mouthed. 4. Blade is dull, wanders, and gets pinched in the cut. 5. Rubber tire on wheel is damaged, glazed, or worn. 6. Wheels are not coplanar. 7. Blade tension is too loose. 8. Blade guides need adjustment. 9. Incorrect blade for bandsaw. 10. The blade has insufficient support. 11. Wheel tires are loaded with metal shavings. 	<ol style="list-style-type: none"> 1. Reduce feed rate, or decrease blade TPI. 2. Adjust blade tracking. 3. Install new blade, and regularly remove tension from blade when not in use. 4. Replace blade, re-secure the workpiece from shifting. 5. Replace or dress rubber tires. 6. Adjust wheels so they are parallel and aligned. 7. Increase blade tension. 8. Adjust blade guides. 9. Install correct blade for machine. 10. Tighten the blade guide as close to the workpiece as possible. 11. Clean wheel tires.
The cut is crooked, the blade wanders, slow cuts, or shows overheating on one side of the cut or the blade.	<ol style="list-style-type: none"> 1. Blade spinning backwards due to machine being wired out of phase (SB1022 only). 2. The feed pressure is too high. 3. Too much side pressure when feeding workpiece. 4. Blade is loading up. 5. Blade installed backwards. 6. Dull blade; missing teeth. 7. Blade too wide for size of radius being cut. 8. The blade speed is wrong. 9. The blade tracking is wrong. 	<ol style="list-style-type: none"> 1. Swap two power incoming power leads (see Page 47). 2. Decrease the feed rate. 3. Feed workpiece straight into the blade. 4. Install a blade with more suitable TPI or different style of teeth. 5. Check blade rotation as described in “test run” and reverse blade if necessary. 6. Replace blade. 7. Install a smaller width blade, or increase blade tension. 8. Adjust feed rate and cutting speed as required. 9. Adjust the blade tracking back to normal.

Symptom	Possible Cause	Possible Solution
Blade dulls prematurely, or metal sticking to the blade.	<ol style="list-style-type: none"> 1. Blade is improperly broken in. 2. The blade gullets are loading up with chips. 3. The blade TPI is too fine for the thick workpiece, and the teeth load up and overheat. 4. The workpiece has hard spots, welds, or scale. 	<ol style="list-style-type: none"> 1. Replace blade, and complete blade break in procedure. 2. Use a blade that has larger gullets to carry out material. 3. Use a coarser-tooth blade, adjust feed rate, adjust blade speed, make sure the brush is working. 4. Replace the blade with a special blade for cutting hardened materials.
Loud, repetitious noise coming from machine.	<ol style="list-style-type: none"> 1. Pulley set screws or keys are missing or loose. 2. Motor fan is hitting the cover. 3. V-belts are defective. 	<ol style="list-style-type: none"> 1. Inspect keys and set screws. Replace or tighten if necessary. 2. Adjust fan cover mounting position, tighten fan, or shim fan cover. 3. Replace V-belts.
Ticking sound when the saw is running.	<ol style="list-style-type: none"> 1. Blade weld contacting blade guides. 2. Blade weld may be failing. 	<ol style="list-style-type: none"> 1. Grind blade weld down smaller. 2. Cut and reweld the blade, or replace the blade.
Blade wears on one side or shows overheating.	<ol style="list-style-type: none"> 1. The blade guides are worn or mis-adjusted. 2. The blade support is inadequate. 3. Wheels are not coplanar. 4. Dull or incorrect blade. 5. Blade is bell-mouthed. 	<ol style="list-style-type: none"> 1. Re-adjust or replace the blade guides. 2. Tighten the blade guide as close to the workpiece as possible. 3. Adjust wheels so they are parallel and aligned. 4. Replace blade. 5. Install new blade.
Vibration when operating or cutting.	<ol style="list-style-type: none"> 1. Loose or damaged blade. 2. Worn wheel bearing. 3. Wheels are not coplanar. 4. Wheel tires worn or incorrectly installed. 5. Bent or dull blade. 6. Wheels out of balance. 7. Loose machine component. 8. Belt has a high spot. 9. Bandsaw blade wheel is bent or out of balance. 	<ol style="list-style-type: none"> 1. Tighten or replace blade. 2. Check/replace wheel bearing. 3. Adjust wheels so they are parallel and aligned. 4. Replace or dress rubber tires. 5. Replace blade. 6. Replace wheels. 7. Tighten loose component. 8. Replace/adjust the V-belt. 9. Check and replace for bad wheel or bearing.

Electrical Safety Instructions

These pages are accurate at the time of printing. In the constant effort to improve, however, we may make changes to the electrical systems of future machines. Study this section carefully. If you see differences between your machine and what is shown in this section, call Technical Support at (360) 734-1540 for assistance BEFORE making any changes to the wiring on your machine.

- 1. Shock Hazard:** It is extremely dangerous to perform electrical or wiring tasks while the machine is connected to the power source. Touching electrified parts will result in personal injury including but not limited to severe burns, electrocution, or death. For your own safety, disconnect machine from the power source before servicing electrical components or performing any wiring tasks!
- 2. Wire Connections:** All connections must be tight to prevent wires from loosening during machine operation. Double-check all wires disconnected or connected during any wiring task to ensure tight connections.
- 3. Modifications:** Using aftermarket parts or modifying the wiring beyond what is shown in the diagram may lead to unpredictable results, including serious injury or fire.
- 4. Motor Wiring:** The motor wiring shown in these diagrams is current at the time of printing, but it may not match your machine. Always use the wiring diagram inside the
- 5. Circuit Requirements:** Connecting the machine to an improperly sized circuit will greatly increase the risk of fire. To minimize this risk, only connect the machine to a power circuit that meets the minimum requirements given in this manual.
- 6. Capacitors/Inverters:** Some capacitors and power inverters store an electrical charge for up to 10 minutes after being disconnected from the power source. To reduce the risk of being shocked, wait at least this long before working on capacitors.
- 7. Wire/Component Damage:** Damaged wires or components increase the risk of serious personal injury, fire, or machine damage. If you notice that any wires or components are damaged while performing a wiring task, replace those wires or components before completing the task.
- 8. Experiencing Difficulties:** If you are experiencing difficulties understanding the information included in this section, contact

Wiring Overview

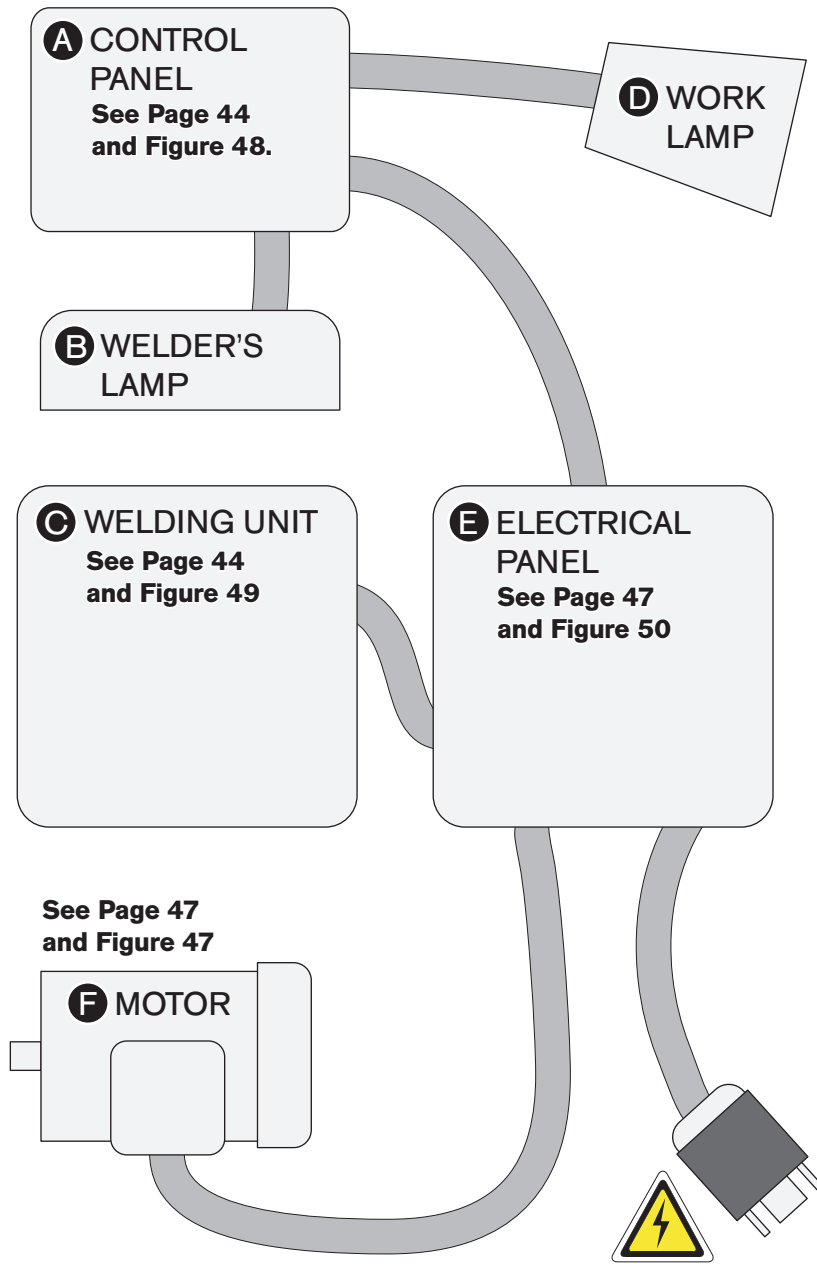

* May Represent Multiple Wires



WIRING DIAGRAM COLOR KEY

BLACK — Bk —	BLUE WHITE — Bw —	RED — Rd —	PINK — Pk —	WHITE — Wt —
BLUE — Bl —	GREEN — Gn —	LIGHT BLUE — Lb —	PURPLE — Pu —	YELLOW GREEN — Yg —
BROWN — Br —	GRAY — Gy —	ORANGE — Or —	TUR-QUIOSE — Tu —	YELLOW — Yl —

NOTICE: The photos and diagrams included in this section are best viewed in color. You can see them in color at www.southbendlathe.com.

SB1021/2 Control Panel & Welding Unit

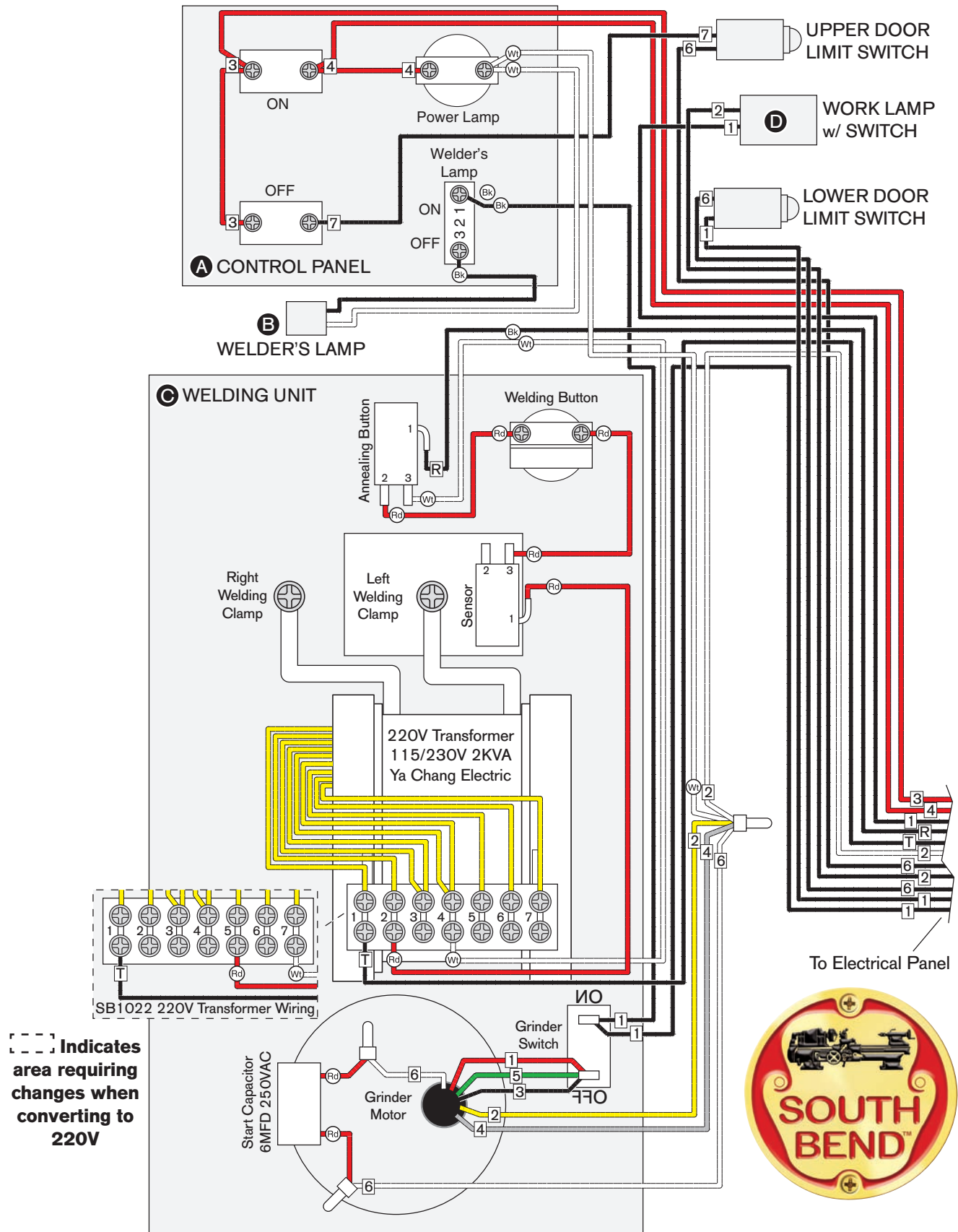

SB1021 110V Electrical Panel, Motor & Cord

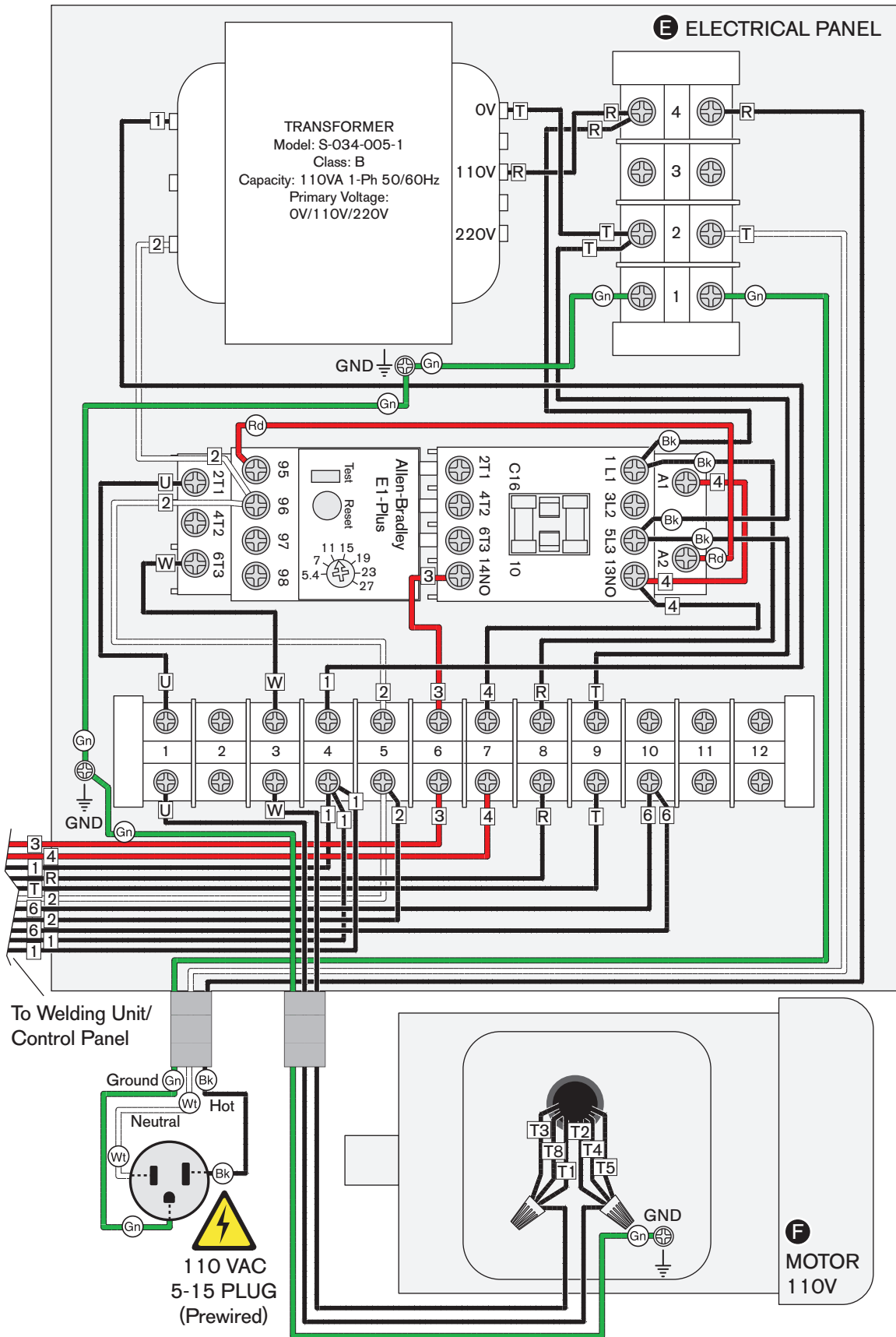

SB1021 220V Electrical Panel, Motor & Cord

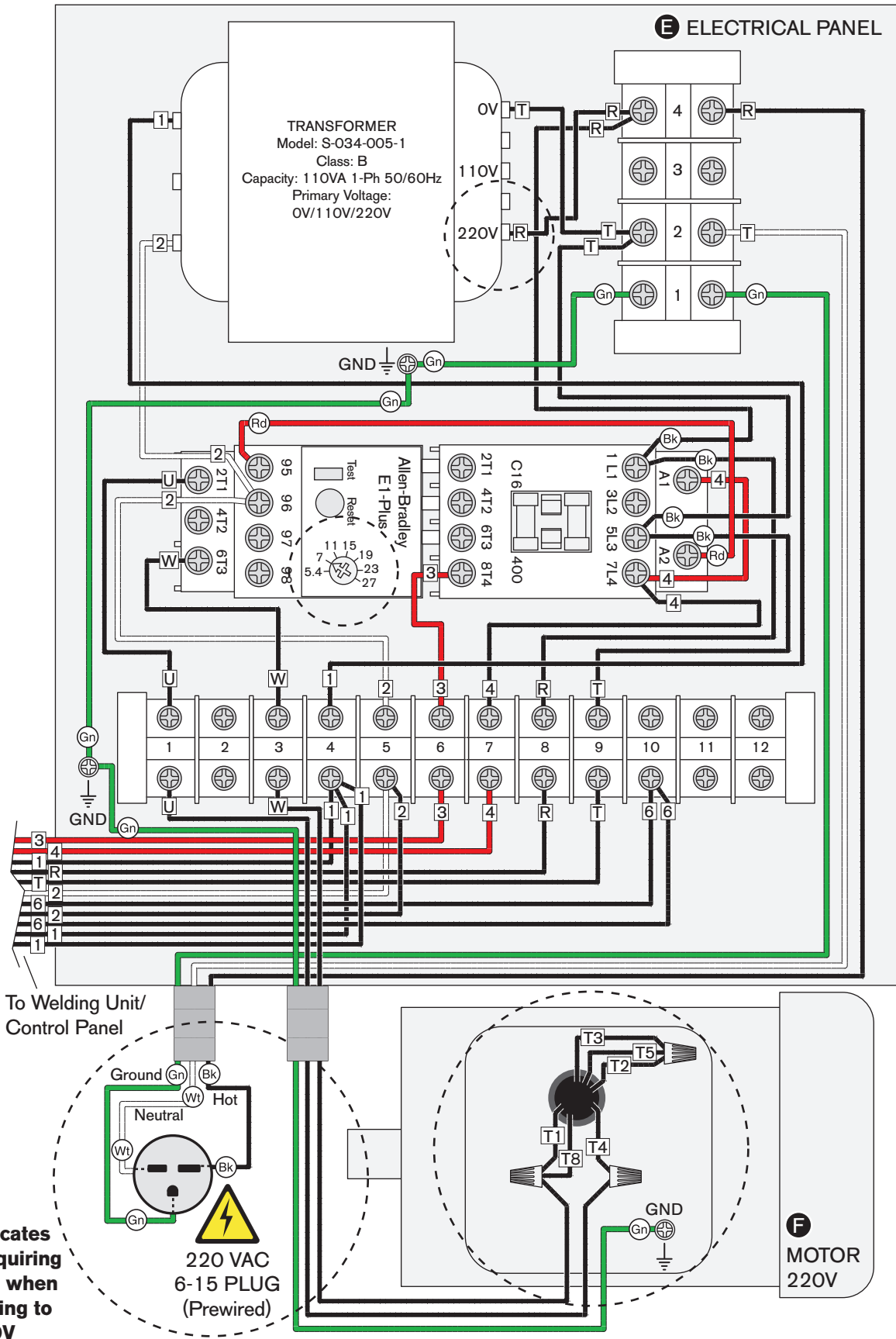

SB1022 220V Electrical Panel, Motor & Cord

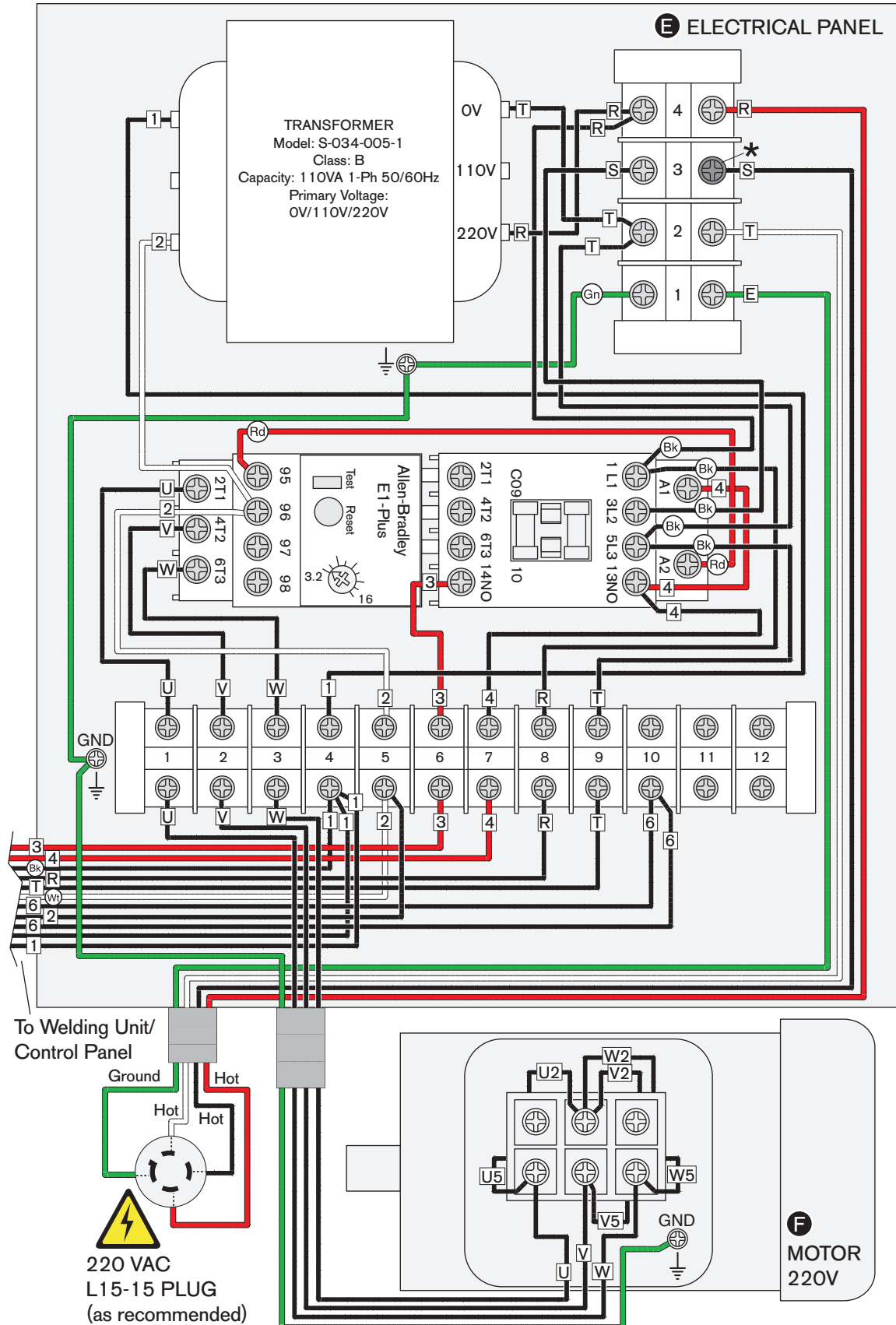

*For Phase Converter Wild Wire (If Used)

Electrical Component Pictures



Figure 47. Motor.

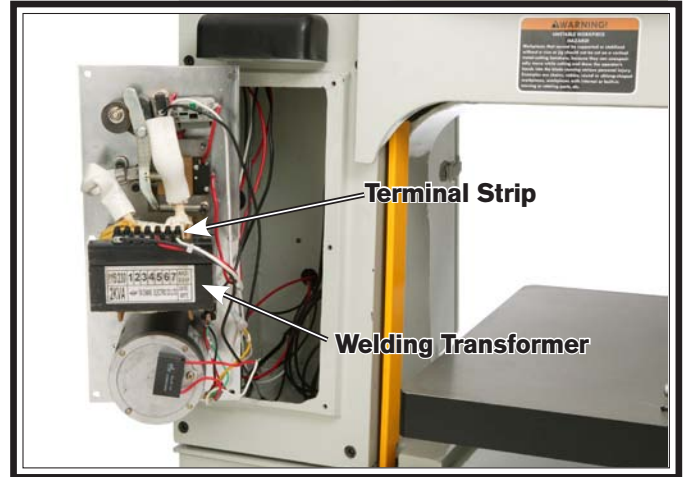

Figure 49. Welding Panel.



Figure 48. Control Panel & Welder's Lamp.



Figure 50. Electrical Box.

Lower Frame Parts List

REF	PART #	DESCRIPTION
1	PSS20M	SET SCREW M8-1.25 X 8
2	PSB1021002	LOCK COLLAR
3	PW04M	FLAT WASHER 10MM
4	PLW06M	LOCK WASHER 10MM
5	PCAP72M	CAP SCREW M10-1.5 X 30
6	PSB1021006	LOCK COLLAR
7	PSB1021007	SHAFT
8	PSB1021008	BEVEL GEAR
9	PSB1021009	BEVEL GEAR
10	PSB1021010	LEADSCREW
11	PSB1021011	RUBBER RING
12	PSB1021012	LEADSCREW NUT
13	PW01M	FLAT WASHER 8MM
14	PCAP14M	CAP SCREW M8-1.25 X 20
15	PSB1021015	FRONT VENT COVER
16	PSB1021016	HANDWHEEL
17	PSB1021017	HANDWHEEL HANDLE
18	PSB1021018	DRIVE WHEEL
19	PSB1021019	RUBBER TIRE
20	PSB1021020	LOCK KNOB
21	PCAP31M	CAP SCREW M8-1.25 X 25
22	PS48M	PHLP HD SCR M4-.7 X 50
23	PSB1021023	LOWER DOOR SAFETY SWITCH
24	PB08M	HEX BOLT M6-1 X 20

REF	PART #	DESCRIPTION
25	PW03M	FLAT WASHER 6MM
26	PLW03M	LOCK WASHER 6MM
27	PFN07M	FLANGE NUT M4-.7
28	PSB1021028	BRACKET
29	PSB1021029	BRUSH
30	PB08M	HEX BOLT M6-1 X 20
31	PLW04M	LOCK WASHER 8MM
32	PS16M	PHLP HD SCR M8-1.25 X 16
33	PCAP31M	CAP SCREW M8-1.25 X 25
34	PW01M	FLAT WASHER 8MM
35	PCAP13M	CAP SCREW M8-1.25 X 30
36	PSB1021036	RIVET 5 X 20
37	PSB1021037	CHIP DEFLECTOR
38	PSB1021038	BASE
39	PCAP14M	CAP SCREW M8-1.25 X 20
40	PSB1021040	LOWER FRAME
41	PSB1021041	LOWER DOOR
42	PNO6M	HEX NUT M5-.8
43	PS03M	PHLP HD SCR M6-1 X 8
44	PSB1021044	DOOR HANDLE
45	PSB1021045	SOUTH BEND NAMEPLATE
46	PS05M	PHLP HD SCR M5-.8 X 8
47	PSB1021047	LOWER REAR COVER
48	PSB1021048	BRACKET

Drive System

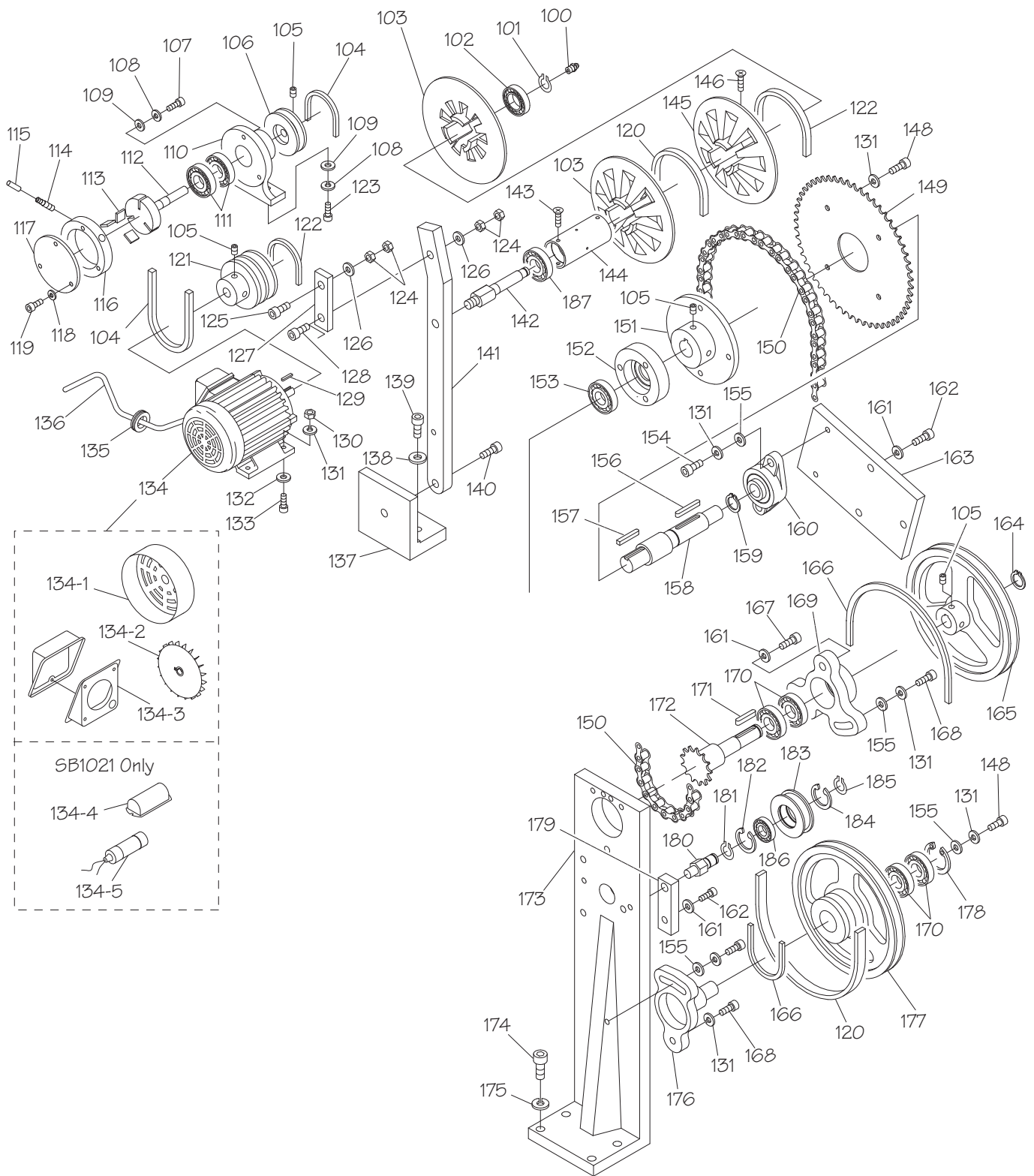

Drive System Parts List

REF	PART #	DESCRIPTION
100	PSB1021100	GREASE FITTING
101	PRO3M	EXT RETAINING RING 12MM
102	P6201Z-N	BALL BEARING 6201 Z NSK
103	PSB1021103	STATIONARY PULLEY
104	PYM26	V-BELT M26
105	PSS20M	SET SCREW M8-1.25 X 8
106	PSB1021106	AIR PUMP PULLEY
107	PCAP02M	CAP SCREW M6-1 X 20
108	PLWO3M	LOCK WASHER 6MM
109	PW03M	FLAT WASHER 6MM
110	PSB1021110	PUMP HOUSING
111	P6201Z-N	BALL BEARING 6201 Z NSK
112	PSB1021112	PUMP ROTOR
113	PSB1021113	ROTOR BLADE
114	PSB1021114	AIR NOZZLE
115	PSB1021115	AIR HOSE
116	PSB1021116	NOZZLE HOUSING
117	PSB1021117	END CAP
118	PLWO3M	LOCK WASHER 6MM
119	PCAP01M	CAP SCREW M6-1 X 16
120	PVA40	V-BELT A40
121	PSB1021121	MOTOR PULLEY
122	PVA36	V-BELT A36
123	PCAP02M	CAP SCREW M6-1 X 20
124	PN09M	HEX NUT M12-1.75
125	PCAP170M	CAP SCREW M12-1.75 X 70
126	PW06M	FLAT WASHER 12MM
127	PSB1021127	CONNECTOR
128	PCAP119M	CAP SCREW M12-1.75 X 55
129	PK23M	KEY 5 X 5 X 25
130	PN03M	HEX NUT M8-1.25
131	PLWO4M	LOCK WASHER 8MM
132	PW01M	FLAT WASHER 8MM
133	PCAP40M	CAP SCREW M8-1.25 X 35
134	PSB1021134	MOTOR 1HP 110/220V 1PH (SB1021)
134	PSB1022134	MOTOR 1HP 220V 3PH (SB1022)
134-1	PSB1021134-1	MOTOR FAN COVER (SB1021)
134-1	PSB1022134-1	MOTOR FAN COVER (SB1022)
134-2	PSB1021134-2	MOTOR FAN (SB1021)
134-2	PSB1022134-2	MOTOR FAN (SB1022)
134-3	PSB1021134-3	MOTOR WIRING BOX (SB1021)
134-3	PSB1021134-3	MOTOR WIRING BOX (SB1022)
134-4	PSB1021134-4	CAPACITOR COVER(SB1021)
134-5	PSB1021134-5	5 CAPACITOR 400M 125V (SB1021)
135	PSB1021135	WIRING GROMMET
136	PSB1021136	MOTOR CORD
137	PSB1021137	BRACKET
138	PLWO6M	LOCK WASHER 10MM

REF	PART #	DESCRIPTION
139	PCAP84M	CAP SCREW M10-1.5 X 35
140	PCAP63M	CAP SCREW M12-1.75 X 60
141	PSB1021141	SUPPORT ARM
142	PSB1021142	SHAFT
143	PFH05M	FLAT HD SCR M5-.8 X 12
144	PSB1021144	SLEEVE
145	PSB1021145	MOVABLE PULLEY
146	PFH05M	FLAT HD SCR M5-.8 X 12
148	PCAP11M	CAP SCREW M8-1.25 X 16
149	PSB1021149	SPROCKET
150	PSB1021150	CHAIN
151	PSB1021151	HUB
152	PSB1021152	BEARING SEAT
153	P6205-OPEN-N	BALL BEARING 6205 OPEN NSK
154	PCAP13M	CAP SCREW M8-1.25 X 30
155	PW01M	FLAT WASHER 8MM
156	PK160M	KEY 6 X 6 X 65
157	PK42M	KEY 6 X 6 X 30
158	PSB1021158	SHAFT
159	PR11M	EXT RETAINING RING 25MM
160	PSB1021160	PILLOW BLOCK BEARING
161	PLWO6M	LOCK WASHER 10MM
162	PCAP84M	CAP SCREW M10-1.5 X 35
163	PSB1021163	PLATE
164	PRO8M	EXT RETAINING RING 19MM
165	PSB1021165	PULLEY
166	PVA47	V-BELT A47
167	PCAP84M	CAP SCREW M10-1.5 X 35
168	PCAP40M	CAP SCREW M8-1.25 X 35
169	PSB1021169	BEARING SEAT
170	P6204Z-N	BALL BEARING 6204 Z NSK
171	PK74M	KEY 6 X 6 X 35
172	PSB1021172	SPROCKET SHAFT
173	PSB1021173	BRACKET
174	PCAP84M	CAP SCREW M10-1.5 X 35
175	PLWO6M	LOCK WASHER 10MM
176	PSB1021176	PIVOT SHAFT
177	PSB1021177	PULLEY
178	PR25M	INT RETAINING RING 47MM
179	PSB1021179	BLOCK
180	PSB1021180	SHAFT
181	PRO5M	EXT RETAINING RING 15MM
182	PR21M	INT RETAINING RING 35MM
183	PSB1021183	PULLEY
184	PR21M	INT RETAINING RING 35MM
185	PRO5M	EXT RETAINING RING 15MM
186	P6202ZZ-N	BALL BEARING 6202 ZZ NSK
187	P6202Z-N	BALL BEARING 6202 Z NSK

Upper Frame

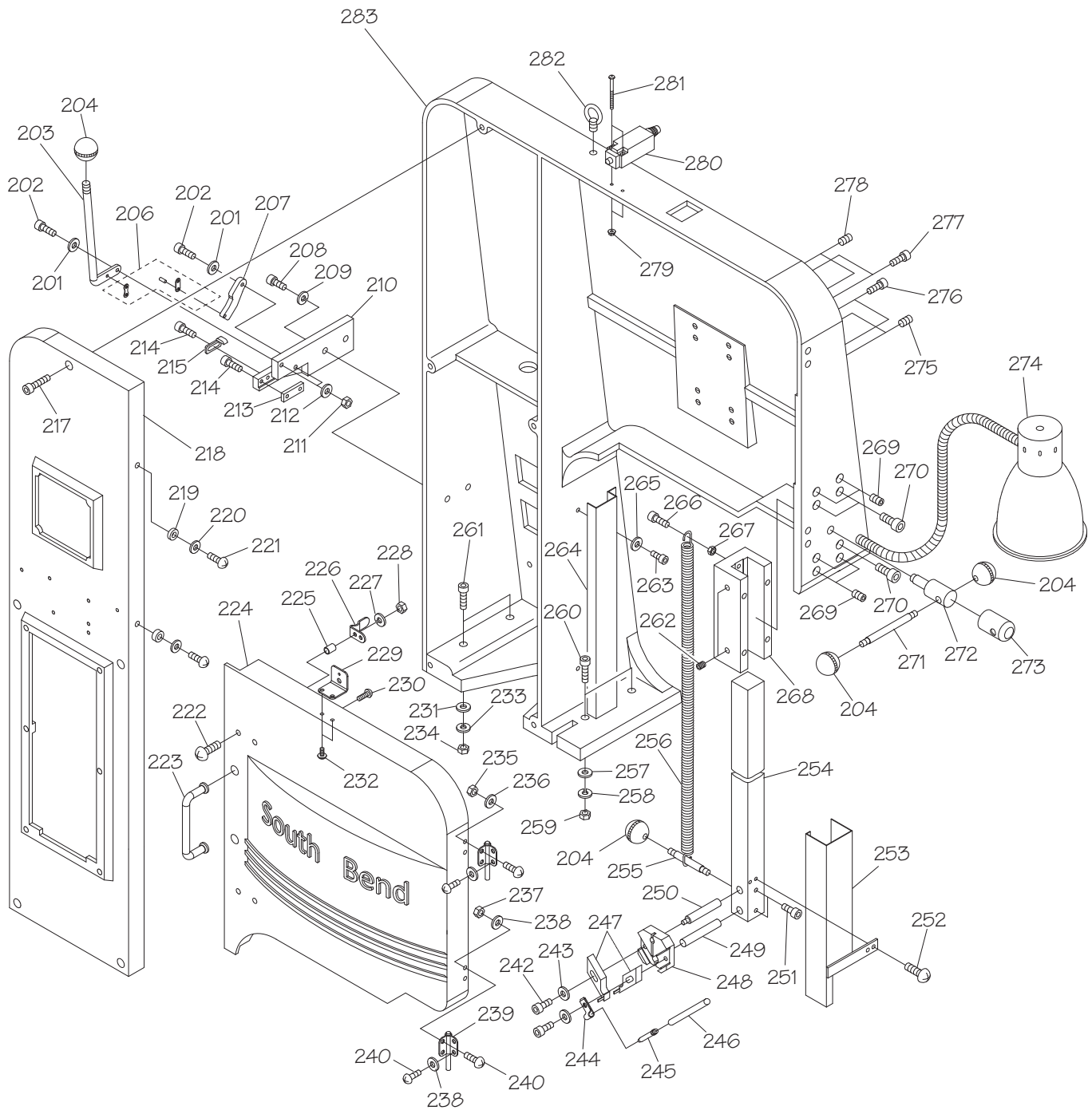

Upper Frame Parts List

REF	PART #	DESCRIPTION
201	PW03M	FLAT WASHER 6MM
202	PCAP06M	CAP SCREW M6-1 X 25
203	PSB1021203	LEVER
204	PSB1021204	KNOB
206	PSB1021206	LOCKING LINK
207	PSB1021207	UPPER SHEAR BLADE
208	PCAP13M	CAP SCREW M8-1.25 X 30
209	PW01M	FLAT WASHER 8MM
210	PSB1021210	SHEAR BRACKET
211	PNO1M	HEX NUT M6-1
212	PW03M	FLAT WASHER 6MM
213	PSB1021213	LOWER SHEAR BLADE
214	PCAP03M	CAP SCREW M5-.8 X 8
215	PSB1021215	ALIGNMENT BRACKET
217	PCAP40M	CAP SCREW M8-1.25 X 35
218	PSB1021218	WELDING STATION COVER
219	PSB1021219	SPACER
220	PLW04M	LOCK WASHER 8MM
221	PS04M	PHLP HD SCR M8-1.25 X 20
222	PS40M	PHLP HD SCR M5-.8 X 16
223	PSB1021223	HANDLE
224	PSB1021224	UPPER DOOR
225	PSB1021225	SPACER
226	PSB1021226	DOOR LATCH
227	PLW01M	LOCK WASHER 5MM
228	PNO6M	HEX NUT M5-.8
229	PSB1021229	SAFETY SWITCH BRACKET
230	PS11M	PHLP HD SCR M6-1 X 16
231	PW04M	FLAT WASHER 10MM
232	PS08M	PHLP HD SCR M5-.8 X 12
233	PLW06M	LOCK WASHER 10MM
234	PNO2M	HEX NUT M10-1.5
235	PNO6M	HEX NUT M5-.8
236	PLW01M	LOCK WASHER 5MM
237	PNO6M	HEX NUT M5-.8
238	PLW01M	LOCK WASHER 5MM
239	PSB1021239	HINGE
240	PS40M	PHLP HD SCR M5-.8 X 16
242	PCAP06M	CAP SCREW M6-1 X 25
243	PW03M	FLAT WASHER 6MM

REF	PART #	DESCRIPTION
244	PSB1021244	HOSE CLAMP
245	PSB1021245	AIR NOZZLE
246	PSB1021246	AIR HOSE
247	PSB1021247	BLADE GUIDE
248	PSB1021248	BLADE GUIDE BRACKET
249	PSB1021249	SPECIAL DOWEL PIN
250	PSB1021250	THREADED PIN
251	PCAP04M	CAP SCREW M6-1 X 10
252	PS11M	PHLP HD SCR M6-1 X 16
253	PSB1021253	UPPER BLADE GUARD
254	PSB1021254	BLADE GUIDE BAR
255	PSB1021255	HANDLE
256	PSB1021256	EXTENSION SPRING
257	PW04M	FLAT WASHER 10MM
258	PLW06M	LOCK WASHER 10MM
259	PNO2M	HEX NUT M10-1.5
260	PCAP70M	CAP SCREW M10-1.5 X 45
261	PCAP71M	CAP SCREW M10-1.5 X 60
262	PSS14M	SET SCREW M8-1.25 X 12
263	PCAP01M	CAP SCREW M6-1 X 16
264	PSB1021264	BLADE COVER
265	PLW03M	LOCK WASHER 6MM
266	PCAP01M	CAP SCREW M6-1 X 16
267	PNO1M	HEX NUT M6-1
268	PSB1021268	BLADE GUIDE BAR HOUSING
269	PSS94M	SET SCREW M10-1.5 X 25
270	PCAP40M	CAP SCREW M8-1.25 X 35
271	PSB1021271	THREADED STUD
272	PSB1021272	LOCKING HUB
273	PSB1021273	LOCKING HUB COVER
274	PSB1021274	WORK LAMP 110V
275	PSS10M	SET SCREW M10-1.5 X 20
276	PCAP13M	CAP SCREW M8-1.25 X 30
277	PCAP13M	CAP SCREW M8-1.25 X 30
278	PSS10M	SET SCREW M10-1.5 X 20
279	PNO4M	HEX NUT M4-.7
280	PSB1021280	UPPER DOOR SAFETY SWITCH
281	PS48M	PHLP HD SCR M4-.7 X 50
282	PSB1021282	LIFTING EYE BOLT
283	PSB1021283	UPPER FRAME

Table & Tensioning System

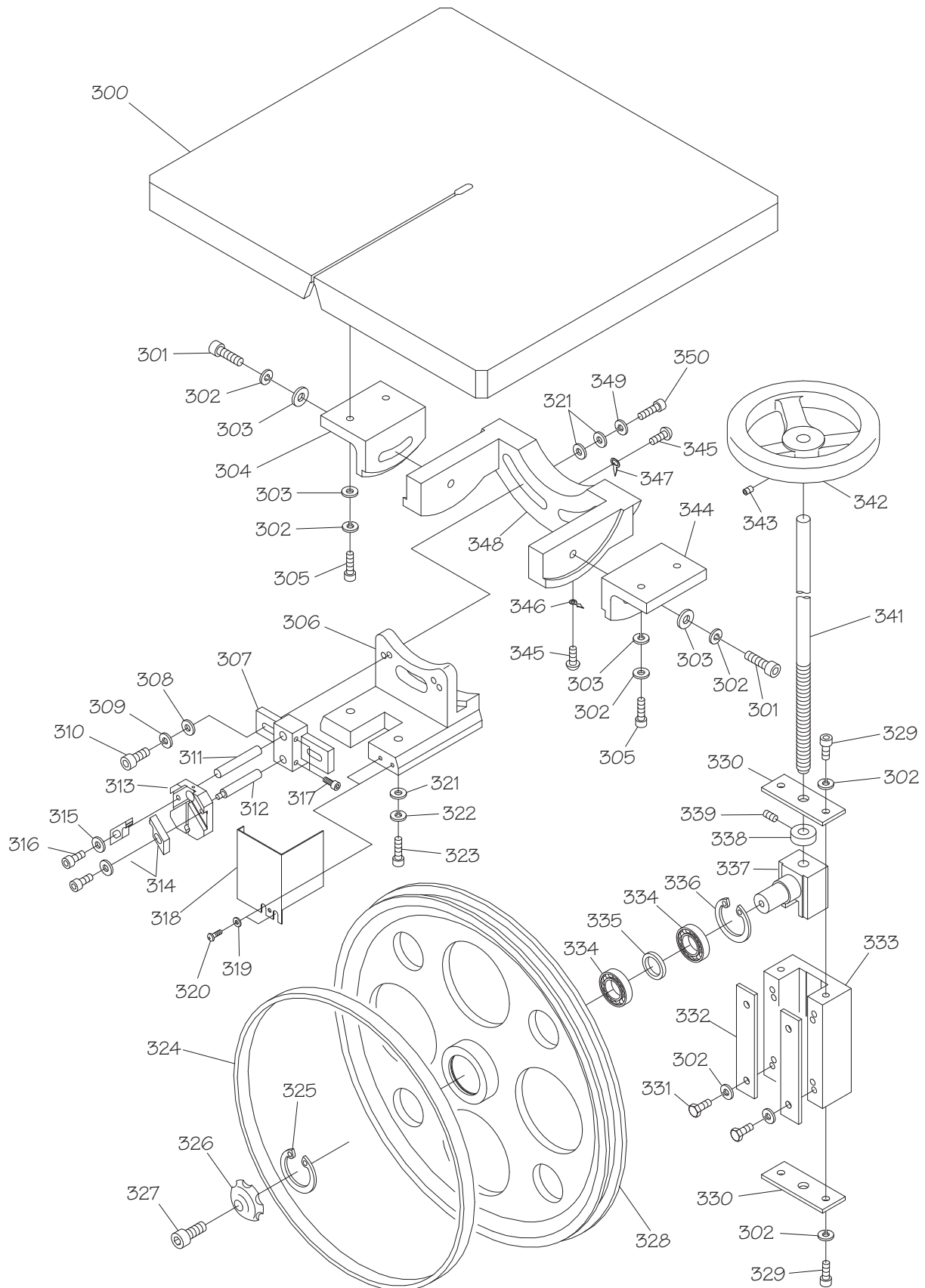
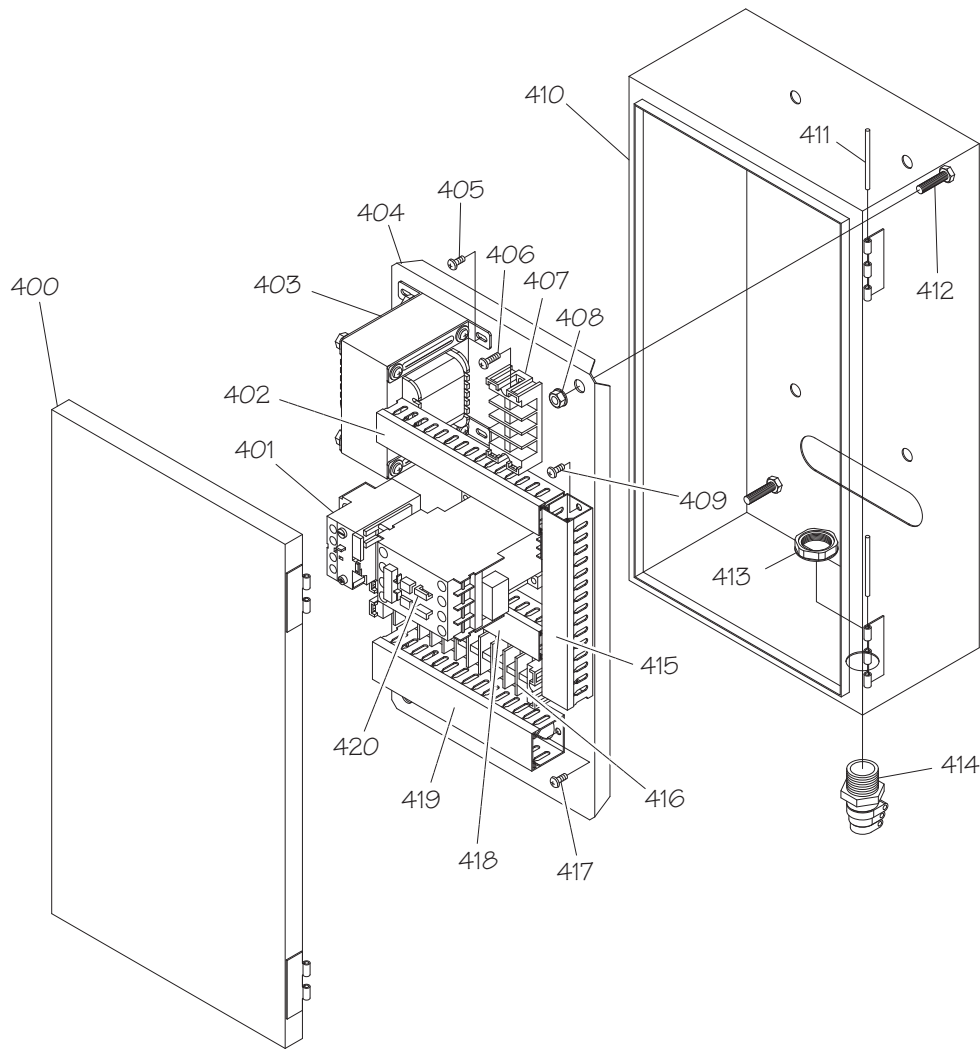

Table & Tensioning System Parts List

REF	PART #	DESCRIPTION
300	PSB1021300	TABLE
301	PCAP05M	CAP SCREW M8-1.25 X 50
302	PLW04M	LOCK WASHER 8MM
303	PW01M	FLAT WASHER 8MM
304	PSB1021304	LEFT TRUNNION BRACKET
305	PCAP40M	CAP SCREW M8-1.25 X 35
306	PSB1021306	TABLE SUPPORT
307	PSB1021307	BLADE GUIDE SUPPORT
308	PW03M	FLAT WASHER 6MM
309	PLW03M	LOCK WASHER 6MM
310	PCAP07M	CAP SCREW M6-1 X 30
311	PSB1021311	THREADED PIN
312	PSB1021312	SPECIAL DOWEL PIN
313	PSB1021313	BLADE GUIDE BRACKET
314	PSB1021314	BLADE GUIDE
315	PW03M	FLAT WASHER 6MM
316	PCAP06M	CAP SCREW M6-1 X 25
317	PCAP04M	CAP SCREW M6-1 X 10
318	PSB1021318	LOWER BLADE GUARD
319	PW02M	FLAT WASHER 5MM
320	PS40M	PHLP HD SCR M5-.8 X 16
321	PW04M	FLAT WASHER 10MM
322	PLW06M	LOCK WASHER 10MM
323	PCAP72M	CAP SCREW M10-1.5 X 30
324	PSB1021324	RUBBER TIRE

REF	PART #	DESCRIPTION
325	PR26M	INT RETAINING RING 52MM
326	PSB1021326	LOCK KNOB
327	PCAP13M	CAP SCREW M8-1.25 X 30
328	PSB1021328	IDLER WHEEL
329	PCAP14M	CAP SCREW M8-1.25 X 20
330	PSB1021330	RETAINING PLATE
331	PB03M	HEX BOLT M8-1.25 X 16
332	PSB1021332	RETAINING PLATE
333	PSB1021333	TRACKING BRACKET
334	P6205Z-N	BALL BEARING 6205 Z NSK
335	PSB1021335	SPACER
336	PR26M	INT RETAINING RING 52MM
337	PSB1021337	IDLER SHAFT
338	PSB1021338	LOCK COLLAR
339	PSS20M	SET SCREW M8-1.25 X 8
341	PSB1021341	TENSION LEADSCREW
342	PSB1021342	HANDWHEEL
343	PSS20M	SET SCREW M8-1.25 X 8
344	PSB1021344	RIGHT TRUNNION BRACKET
345	PS08M	PHLP HD SCR M5-.8 X 12
346	PSB1021346	POINTER
347	PSB1021347	POINTER
348	PSB1021348	TABLE TRUNNION
349	PW04M	FLAT WASHER 10MM
350	PCAP90M	CAP SCREW M10-1.5 X 55

Electrical Cabinet



REF	PART #	DESCRIPTION
400	PSB1021400	CABINET DOOR
401	PSB1021401	OL RELAY AB 193-EEEE 5.4-27A (SB1021)
401	PSB1022401	OL RELAY AB 193-EEDB 3.2-16A (SB1022)
402	PSB1021402	WIRE LOOM
403	PSB1021403	TRANSFORMER YA CHANG 220V 1A
404	PSB1021404	ELECTRICAL PANEL
405	PSO7M	PHLP HD SCR M4-.7 X 8
406	PSO2M	PHLP HD SCR M4-.7 X 12
407	PSB1021407	TERMINAL BLOCK 8P
408	PNO1M	HEX NUT M6-1
409	PSO7M	PHLP HD SCR M4-.7 X 8
410	PSB1021410	ELECTRICAL CABINET

REF	PART #	DESCRIPTION
411	PSB1021411	HINGE PIN
412	PB47M	HEX BOLT M6-1 X 40
413	PSB1021413	STRAIN RELIEF NUT
414	PSB1021414	STRAIN RELIEF
415	PSB1021415	WIRE LOOM
416	PSB1021416	TERMINAL BLOCK 24P
417	PSO7M	PHLP HD SCR M4-.7 X 8
418	PSB1021418	WIRE LOOM
419	PSB1021419	WIRE LOOM
420	PSB1021420	CONT. AB 100-C16-400 110V (SB1021)
420	PSB1022420	CONT. AB 100-C09-400 110V (SB1022)

Welder & Control Panel

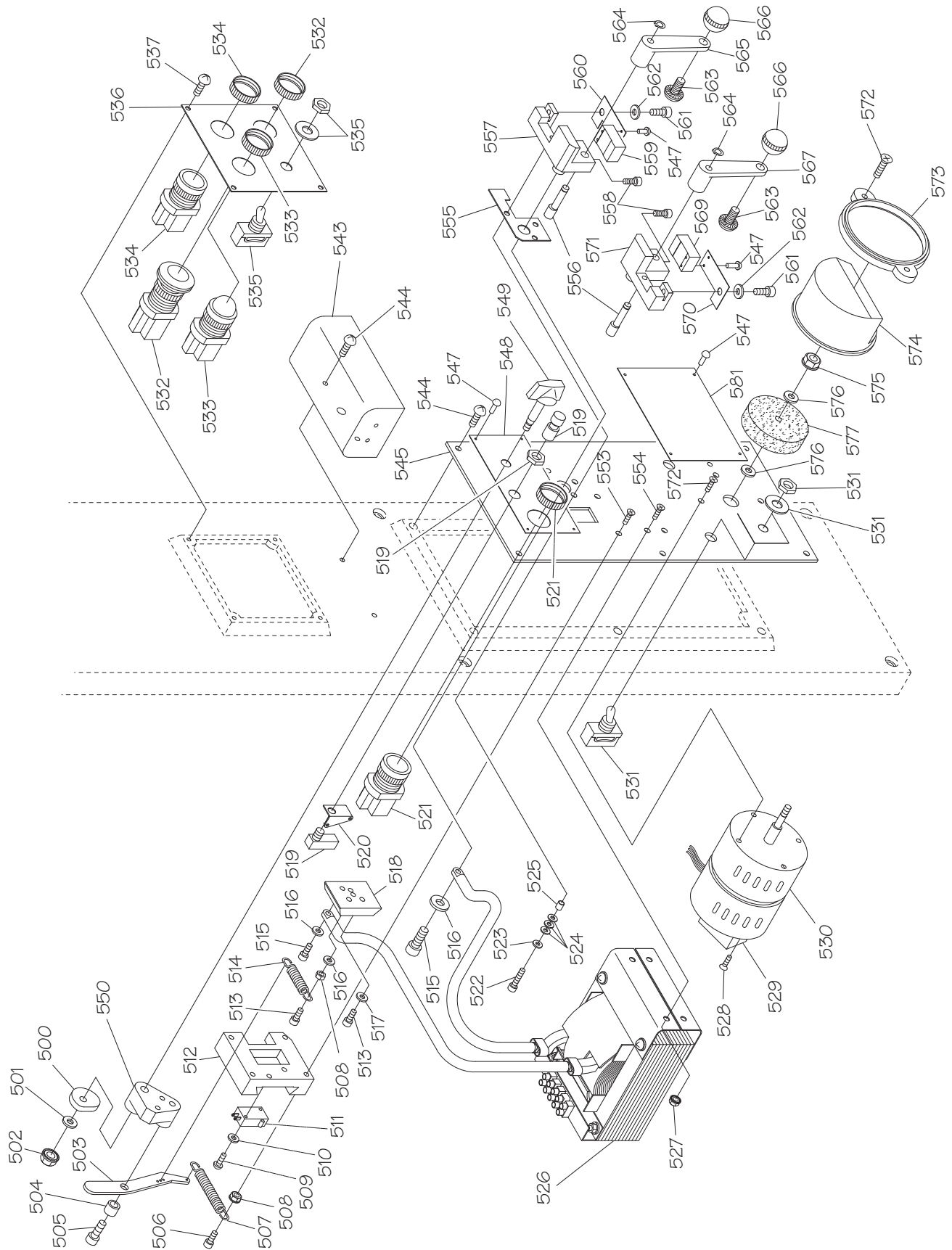

Welder & Control Panel Breakdown

REF	PART #	DESCRIPTION
500	PSB1021500	CAM
501	PW03M	FLAT WASHER 6MM
502	PNO1M	HEX NUT M6-1
503	PSB1021503	SPRING ARM
504	PSB1021504	SPACER
505	PCAP01M	CAP SCREW M6-1 X 16
506	PCAP38M	CAP SCREW M5-.8 X 25
507	PSB1021507	LOWER EXTENSION SPRING
508	PNO6M	HEX NUT M5-.8
509	PS48	PHLP HD SCR 5-40 x 3/4
510	PLW1	LOCK WASHER #5
511	PSB1021511	SWITCH
512	PSB1021512	SLIDE SEAT
513	PCAP38M	CAP SCREW M5-.8 X 25
514	PSB1021514	UPPER EXTENSION SPRING
515	PCAP03M	CAP SCREW M5-.8 X 8
516	PW02M	FLAT WASHER 5MM
517	PLW01M	LOCK WASHER 5MM
518	PSB1021518	SLIDE BLOCK
519	PSB1021519	ANNEAL SWITCH
520	PSB1021520	ANNEAL SWITCH BRACKET
521	PSB1021521	WELD SWITCH
522	PCAP24M	CAP SCREW M5-.8 X 16
523	PW02M	FLAT WASHER 5MM
524	PSB1021524	INSULATING WASHER 5MM
525	PSB1021525	INSULATING SPACER 5MM
526	PSB1021526	WELDING TRANSFORMER
527	PNO6M	HEX NUT M5-.8
528	PFH30M	FLAT HD SCR M5-.8 X 8
529	PSB1021529	GRINDER CAPACITOR
530	PSB1021530	GRINDER MOTOR
531	PSB1021531	TOGGLE SWITCH
532	PSB1021532	OFF SWITCH
533	PSB1021533	POWER LAMP
534	PSB1021534	ON SWITCH

REF	PART #	DESCRIPTION
535	PSB1021535	TOGGLE SWITCH
536	PSB1021536	CONTROL PANEL
537	PS09M	PHLP HD SCR M5-.8 X 10
543	PSB1021543	LAMP COVER
544	PS09M	PHLP HD SCR M5-.8 X 10
545	PSB1021545	WELDING PANEL
547	PSB1021547	RIVET M2 X 6
548	PSB1021548	WELDING CONTROL PANEL
549	PSB1021549	PRESSURE KNOB
550	PSB1021550	SPRING ARM BRACKET
553	PFH01M	FLAT HD SCR M5-.8 X 15
554	PFH05M	FLAT HD SCR M5-.8 X 12
555	PSB1021555	JAW INSULATOR
556	PSB1021556	CAM PIVOT SHAFT
557	PSB1021557	RIGHT ELECTRODE
558	PCAP33M	CAP SCREW M5-.8 X 12
559	PSB1021559	RIGHT LOWER JAW
560	PSB1021560	RIGHT CONNECTING PLATE
561	PCAP97M	CAP SCREW M5-.8 X 6
562	PLW01M	LOCK WASHER 5MM
563	PSB1021563	SPECIAL SCREW M8-1.25 X 16
564	PR73M	EXT RETAINING RING 5MM
565	PSB1021565	RIGHT CLAMP LEVER
566	PSB1021566	KNOB
567	PSB1021567	LEFT CLAMP LEVER
569	PSB1021569	LEFT LOWER JAW
570	PSB1021570	LEFT CONNECTING PLATE
571	PSB1021571	LEFT ELECTRODE
572	PFH07M	FLAT HD SCR M5-.8 X 10
573	PSB1021573	GUARD RETAINING RING
574	PSB1021574	GRINDING WHEEL GUARD
575	PNO5	HEX NUT 1/4-20
576	PW06	FLAT WASHER 1/4
577	PSB1021577	GRINDING WHEEL 1/4 X 5/8 X 2-1/2
581	PSB1021581	WELDING INSTRUCTION PLATE

Machine Labels

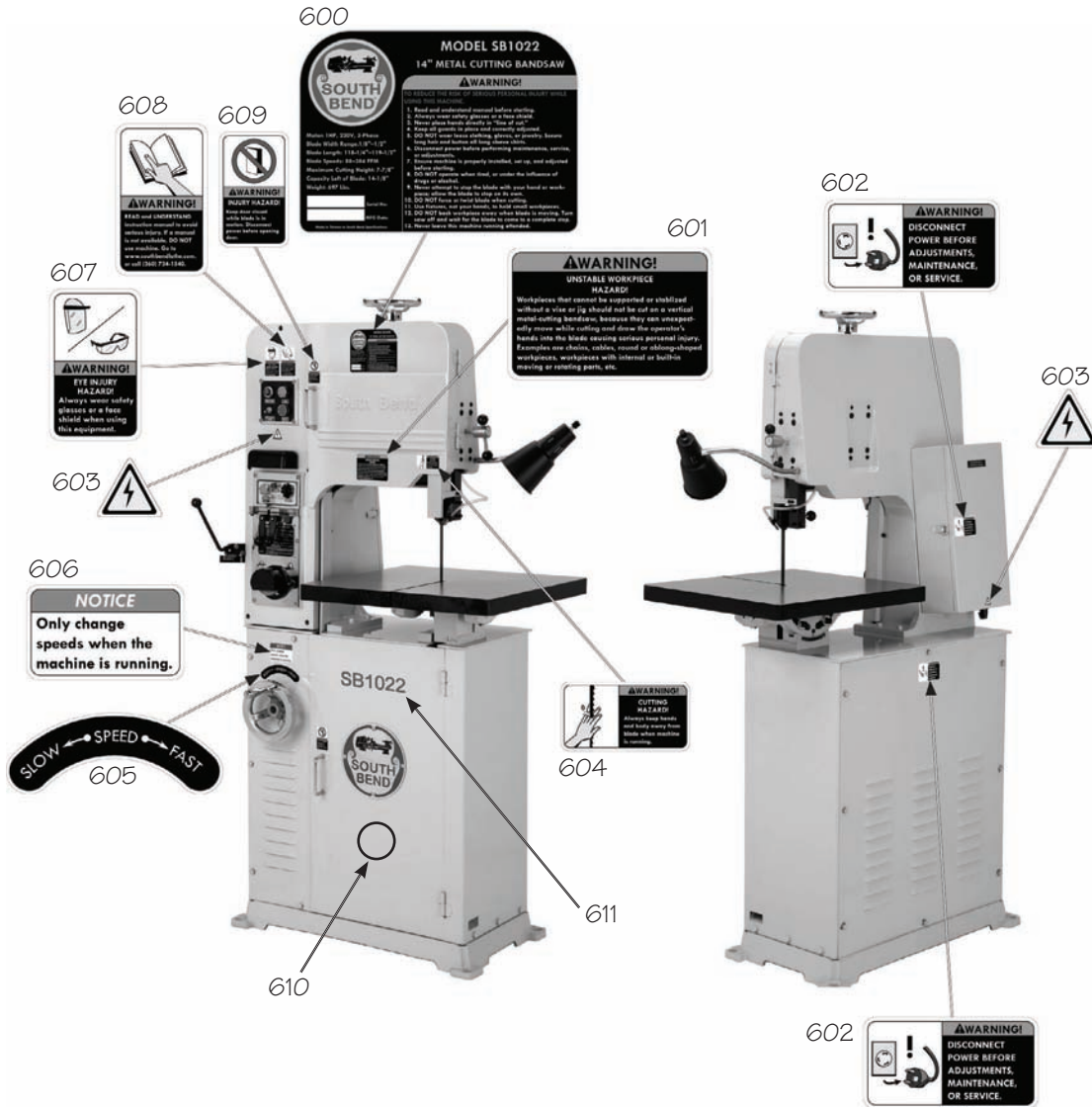

REF	PART #	DESCRIPTION
600	PSB1021600	MACHINE ID LABEL (SB1021)
600	PSB1022600	MACHINE ID LABEL (SB1022)
601	PSB1021601	UNSTABLE W/P HAZARD LABEL
602	PSBLABEL02VS	DISCONNECT WARNING LABEL
603	PSBLABEL15M	ELECTRICITY LABEL
604	PSB1021604	CUTTING HAZARD LABEL
605	PSB1021605	SPEED LABEL

REF	PART #	DESCRIPTION
606	PSB1021606	SPEED CHANGE NOTICE LABEL
607	PSBLABEL03VL	EYE INJURY HAZARD LABEL
608	PSBLABEL01VL	READ MANUAL LABEL
609	PSBLABEL13VS	DOOR INJURY HAZARD LABEL
610	PSB1021610	SOUTH BEND GRAY TOUCH-UP PAINT
611	PSB1021611	MODEL NUMBER LABEL (SB1021)
611	PSB1022611	MODEL NUMBER LABEL (SB1022)

⚠ WARNING

The safety labels provided with your machine are used to make the operator aware of the machine hazards and ways to prevent injury. The owner of this machine **MUST** maintain the original location and readability of these safety labels. If any label is removed or becomes unreadable, **REPLACE** that label before using the machine again. Contact South Bend Lathe Co. at (360) 734-1540 or www.southbendlathe.com to order new labels.

Warranty

This quality product is warranted by South Bend Lathe Company to the original buyer for one year from the date of purchase. This warranty does not apply to consumable parts, or defects due to any kind of misuse, abuse, negligence, accidents, repairs, alterations or lack of maintenance. We do not reimburse for third party repairs. In no event shall we be liable for death, injuries to persons or property, or for incidental, contingent, special or consequential damages arising from the use of our products.

We do not warrant or represent that this machine complies with the provisions of any law, act, code, regulation, or standard of any domestic or foreign government, industry, or authority. In no event shall South Bend's liability under this warranty exceed the original purchase price paid for this machine. Any legal actions brought against South Bend Lathe Company shall be tried in the State of Washington, County of Whatcom.

This is the sole written warranty for this machine. Any and all warranties that may be implied by law, including any merchantability or fitness, for any purpose, are hereby limited to the duration of this warranty. To take advantage of this warranty, contact us by mail or phone to give us the details of the problem you are having.

Thank you for your business and continued support.



South Bend Lathe Co.
P.O. Box 2027
Bellingham, WA 98227

PHONE: (360) 734-1540 (Administrative Offices)

FAX: (360) 676-1075 (International)

FAX: (360) 734-1639 (USA only)

southbendlathe.com

